

# *Burmester*

AMBIENCE 31



Operating Manual



---

# INHALTSVERZEICHNIS

<b>1</b>	<b>ABOUT THIS DEVICE</b>	<b>5</b>
<b>2</b>	<b>ABOUT THESE OPERATING INSTRUCTIONS</b>	<b>6</b>
2.1	Symbols and text labels used	6
2.2	Meaning of warning symbols and words	6
<b>3</b>	<b>IMPORTANT SAFETY INFORMATION</b>	<b>7</b>
3.1	Unpacking	7
3.2	Set-up	7
3.3	Connecting	7
3.4	Start-up	7
3.5	Operation	7
<b>4</b>	<b>UNPACKING AND SETTING UP THE LOUDSPEAKERS</b>	<b>8</b>
4.1	Unpacking	8
4.1.1	Scope of delivery	8
4.1.2	Packaging	8
4.2	The speaker at a glance	9
4.3	Set-up	10
4.3.1	Correct positioning	10
4.3.2	Using spikes	11
<b>5</b>	<b>CONNECTING THE LOUDSPEAKERS</b>	<b>12</b>
5.1	Connection terminals	12
5.2	Connection cables	13
5.3	Requirements for amplifiers	13
5.4	Classic connection	13
5.5	Bi-wiring connection	14
5.6	Bi-amping connection	15
5.6.1	Vertical bi-amping	15
5.6.2	Horizontal bi-amping	16
5.7	Bi-amping with mono power amplifiers	17

---

<b>6</b>	<b><u>OPERATING THE LOUDSPEAKERS</u></b>	<b>18</b>
6.1	Improving your audio – ambience tweeter	18
<b>7</b>	<b><u>MAINTENANCE, REPAIR, AND CARE</u></b>	<b>18</b>
<b>8</b>	<b><u>DISPOSAL</u></b>	<b>18</b>
<b>9</b>	<b><u>WARRANTY</u></b>	<b>19</b>
<b>10</b>	<b><u>TROUBLESHOOTING</u></b>	<b>19</b>
<b>11</b>	<b><u>TECHNICAL DATA</u></b>	<b>19</b>

Dear Music Enthusiast,

Congratulations on your selection and thank you for your trust.

You have chosen a product that combines absolute fidelity and uncompromising quality with technical innovation and maximum flexibility.

Please read through these operating instructions at least once before initially installing the product so you can fully benefit from all the functions of this truly high-fidelity device. Should any of your questions remain unanswered, please contact your specialist dealer or us directly.

Talk to us about any special requests you may have – even if they seem exceptional. We love accepting technically feasible challenges.

We wish you many hours of high-fidelity listening.

The Burmester Team

## 1 ABOUT THIS DEVICE

The Burmester Ambience 31 loudspeaker owes its lean elegance but elemental bass power to the partitioning of its diaphragm surface into one woofer and one woofer/mid-range driver per speaker. A bass reflex port provides support in the lowest range.

A new Air Motion Transformer (AMT) was custom-developed for the high range. For many years, the Burmester AMTs have been regarded as a benchmark for ultimate precision, neutrality, power handling, and dynamics in the high frequency range.

The Burmester Ambience 31 loudspeaker owes its spacious sound talents to a second, back-firing AMT on the rear of the cabinet, which optimizes the omnidirectional behavior and makes the listening room an even more integral part of the sound experience. With continuous level adjustment, the Burmester Ambience 31 can be optimally adjusted to the individual space and your sound preferences.

### Highlights:

- Custom-developed Air Motion Transformer (AMT)
- Second AMT tweeter (Ambience tweeter), back-firing and continuously adjustable
- 2 ½-way system

## 2 ABOUT THESE OPERATING INSTRUCTIONS

These operating instructions describe the set-up, connection and operation of the Burmester Ambience 31 loudspeaker (referred to in the following as “loudspeaker”, “speaker”, or “BA31”).

**Please note the following:**



- ▶ Read and follow the information given, in particular the safety information and warnings.
- ▶ Save these operating instructions.

### 2.1 Symbols and text labels used

✓	<p><b>Prerequisite</b> Designates a requirement which must be fulfilled before a subsequent action can be taken.</p>
▶	<p><b>Action step</b> Designates an individual action step.</p>
1. 2. 3.	<p><b>Sequence of actions</b> Designates a sequence of action steps which have to be performed in the given order.</p>

### 2.2 Meaning of warning symbols and words

This document uses the following warning symbols and words:

	The general danger symbol, in conjunction with the warning words CAUTION, WARNING, and DANGER, serves to warn against the risk of severe injuries. Follow all subsequent instructions to prevent serious or fatal injuries.
	The lightning symbol, in conjunction with the warning word DANGER, serves to warn against lethal voltage.
<b>NOTICE</b>	The warning word NOTICE indicates a danger that can lead to damage to or destruction of the device.
<b>CAUTION</b>	The warning word CAUTION indicates a danger that poses a low or medium risk of injury.
<b>WARNING</b>	The warning word WARNING indicates a danger that can lead to death or severe injuries.

**3****IMPORTANT SAFETY INFORMATION**

Please read through the operating instructions for your speaker completely and save them. Should you have any questions, please contact your specialist dealer.

**3.1 Unpacking**

The speakers are very heavy components. To prevent injuries, the speakers should only be unpacked and set up by individuals who are experienced in handling heavy loads.

To prevent damage to the housings, do not use sharp or pointed objects to remove the packaging.

The speakers are enclosed in a plastic bag on delivery. Keep this bag out of the reach of children to prevent suffocation.

**3.2 Set-up**

Observe the following during set-up:

- The spikes provided on delivery can result in injuries and can damage flooring. Exercise caution when installing the spikes and use the protective disks provided on delivery.
- Avoid direct sunlight.
- Avoid excessive heat, cold, moisture, and dust.
- Do not expose the speaker to dripping water or spray water and do not place any containers holding liquids on your speaker.
- Do not place any open ignition sources, such as burning candles, on the speaker.

**3.3 Connecting**

- ▶ Switch off amplifiers before connecting them to the speakers.

**3.4 Start-up**

- ▶ After connecting the amplifier, adjust its volume to a low setting before switching it on.

**3.5 Operation**

- ▶ Do not listen to music at a high volume for extended periods. Very loud signals can cause hearing damage.

## 4 UNPACKING AND SETTING UP THE LOUDSPEAKERS

### CAUTION

#### **Heavy weight of speakers**

**The speakers are very heavy and can result in injuries in case of falling or toppling.**

- ▶ The speakers should only be unpacked and set up by individuals who are experienced in handling heavy loads.
- ▶ Allow a second person to help you during unpacking and set-up if need be.

### 4.1 Unpacking

- ▶ Please make sure the package contents are complete and undamaged.

Should parts be missing or if you detect damage while unpacking the speaker, please do not connect it. Instead, contact your authorized specialist dealer.

#### 4.1.1 Scope of delivery

The scope of delivery includes:

- BA31 speaker with packaging
- 4 spikes
- 4 protective disks
- 1 set of operating instructions
- 1 set of warranty documents

#### 4.1.2 Packaging

### WARNING

#### **Danger of suffocation**

**The speakers are packaged in a plastic bag on delivery. This bag can present a suffocation hazard for children.**

- ▶ Keep the plastic bag out of the reach of children.

We recommend saving the original packaging for transportation, such as when moving, etc.



## 4.2 The speaker at a glance

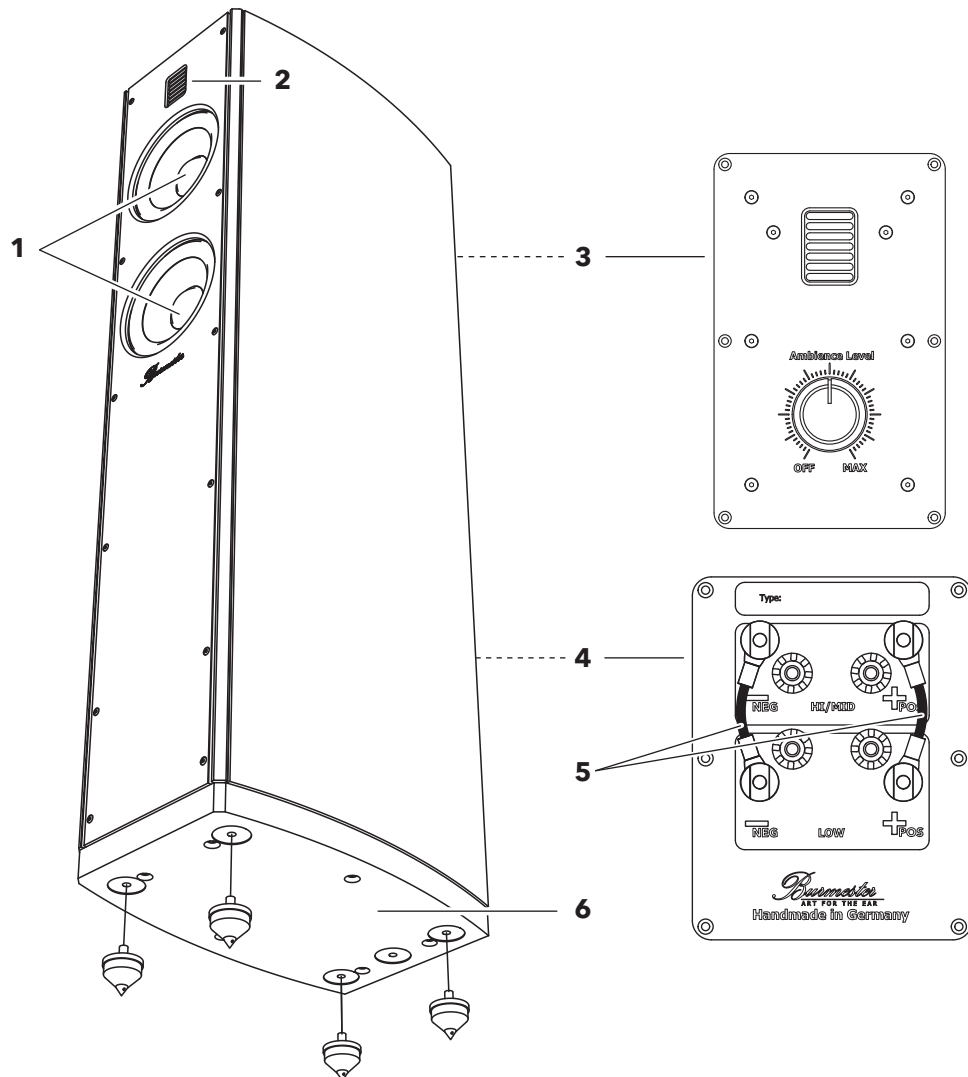

1	<b>Low-Mid-range drivers</b>
2	<b>Tweeter</b>
3	<b>Second tweeter</b> Back-firing tweeter to reinforce the acoustic environment With control for continuous level adjustment
4	<b>Connector panel</b> Separate connections for woofer and mid-range/tweeter units with terminals for cable lugs and sockets for banana plugs
5	<b>Jumper plugs</b> The jumpers are installed on delivery.
6	<b>Base plate</b> With threaded inserts for spikes

## 4.3 Set-up

Carefully remove the speakers from the transportation packaging and place them in a suitable location. Avoid direct sunlight, dust, and moisture.

### 4.3.1 Correct positioning

The speakers can be easily integrated in virtually any interior. Optimal acoustics can be achieved by positioning your speakers so that they create an equilateral triangle, with the third point being the listener (as seen from above).

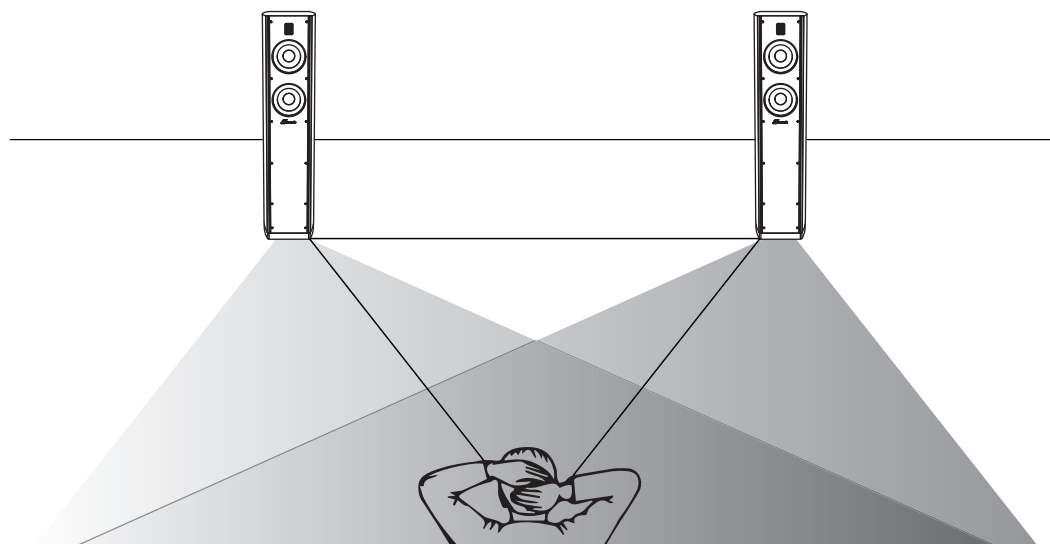

The spatial audio reproduction increases with a greater distance between the speakers and the wall, while the bass reproduction decreases. The BA31 speakers are designed so that they do not need to be positioned near a wall to accentuate the bass. However, since listening spaces have very different acoustic properties, positioning near a wall may improve the acoustics in some cases.

The two speakers should be placed 2.50 m to 4.00 m apart. Ideally, the space between them should remain free of any other objects. In a room with a rectangular floor space, it is preferable to place the speakers on the longer wall instead of the shorter wall. Similarly, positioning in the "hard" acoustic area (along smooth walls and windows) of the room is preferable to the "soft" acoustic area (muted by upholstered furniture, books and carpet). This especially applies for the ambience tweeter (see „Improving your audio – ambience tweeter“ on page 18).

#### NOTE

If you have a television set with a cathode ray tube, maintain a minimum distance of 50 cm between the speakers and the TV set. Otherwise, the magnetic fields of the speakers can cause isolated color changes in your TV image.

### 4.3.2 Using spikes

#### **⚠ CAUTION**

##### **Danger of injuries and damage caused by spikes**

**Combined with the heavy weight of the speakers, the spike tips can cause injuries and damage.**

- ▶ Be careful when mounting the spikes in order to prevent injuries.
- ▶ Always work together with at least one other person to position the speakers.
- ▶ Place the protective disks under the spikes before moving the speaker into an upright position.

When using the speakers on resonant flooring (such as parquet or laminate floors), Burmester recommends the use of spikes for acoustic decoupling from the floor. Suitable spikes are included in the scope of delivery.

The undersides of the housings are each equipped with five threaded inserts for screwing in the spikes. Four spikes (A, B, C, D) are ideal for even surfaces. Uneven surfaces can be compensated by using three spikes (A, B, E).

You can adjust the height of the spikes to improve speaker stability.

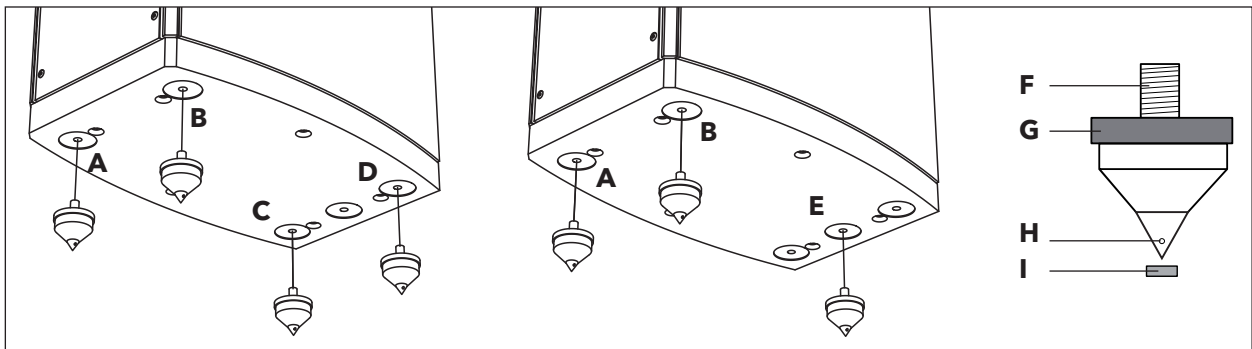

##### **Installing the spikes:**

1. Lay the speaker down on a soft surface (e.g. carpet or blanket).
2. Screw the spike threads (F) into the inserts/bushings in the housing base plate.
3. Together with an assistant, carry the speaker to the planned position in your listening room.
4. Position the small protective disks (I) directly under the spikes and then move the speaker into an upright position. This prevents damage to the flooring.

If the speakers are not stable and steady, the spike with the least contact to the floor should be unscrewed slightly.

##### **Adjusting the height:**

1. Insert the small adjusting rod into the opening (H) at the tip of the spike that you would like to adjust.
2. Turn the spike counterclockwise (as seen from below) until the speaker stands securely without wobbling.
3. Then tighten the knurled nuts (G) on all spikes manually by turning them clockwise (as seen from below) so that the spikes rest in a stable position on the housing.

## 5 CONNECTING THE LOUDSPEAKERS

- ▶ Read the operating instructions for the other connected components before connecting the speakers.
- ▶ Make sure the polarity is correct: red = positive, blue or black = negative



### ⚠ WARNING

#### Dangerous voltage on the connection terminals

The terminals may carry dangerous voltage during operation.

- ▶ Switch off all of your audio system components and do not switch them back on until all connections are properly established.
- ▶ Do not touch the terminals while the amplifier power is on and the speaker is connected.

### NOTICE

#### Damage caused by improper connections

A short circuit or an improper connection can damage the speakers and other components.

- ▶ Switch off the power amplifiers before connecting the speakers. This prevents short circuits due to cables that are not yet connected at both ends.
- ▶ First connect the cables to the speakers and then to the power amplifiers.
- ▶ Only connect the speaker cables to the proper terminals on an audio amplifier. Never insert the connection cables into an electrical outlet, since this will destroy the speakers.

### 5.1 Connection terminals

Burmester uses the same terminals for its speakers as it does for its power amplifiers. These terminals have proven their worth many times over in terms of function and sound quality. Cable lugs soldered to the stripped speaker cable ends ensure optimal contact and minimal contact resistance. Sockets (1) for banana plugs are also provided.

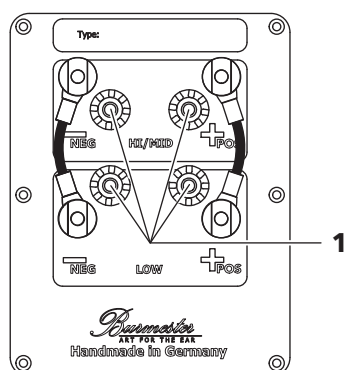

Both variants enable bi-wiring and bi-amping.

## 5.2 Connection cables

Burmester recommends the use of cables with a large cross-sectional area to connect the speakers to the power amplifiers. The large cable cross-sectional area preserves the damping factor of the amplifiers for optimal speaker control.

For the best results, we recommend the use of original Burmester speaker cables, which have the same electrical and acoustic properties as the wiring inside Burmester speakers and amplifiers.

## 5.3 Requirements for amplifiers

The BA31 can produce superior acoustics, even in large spaces. Nonetheless, high-quality power amplifiers are required to prevent clipping (distortion caused by overdriving an amplifier) and speaker damage.

## 5.4 Classic connection

This is the most common connection type. Each power amplifier channel is connected to a speaker using a 2-wire cable. A dual-channel (stereo) amplifier is then required for stereo sound reproduction.

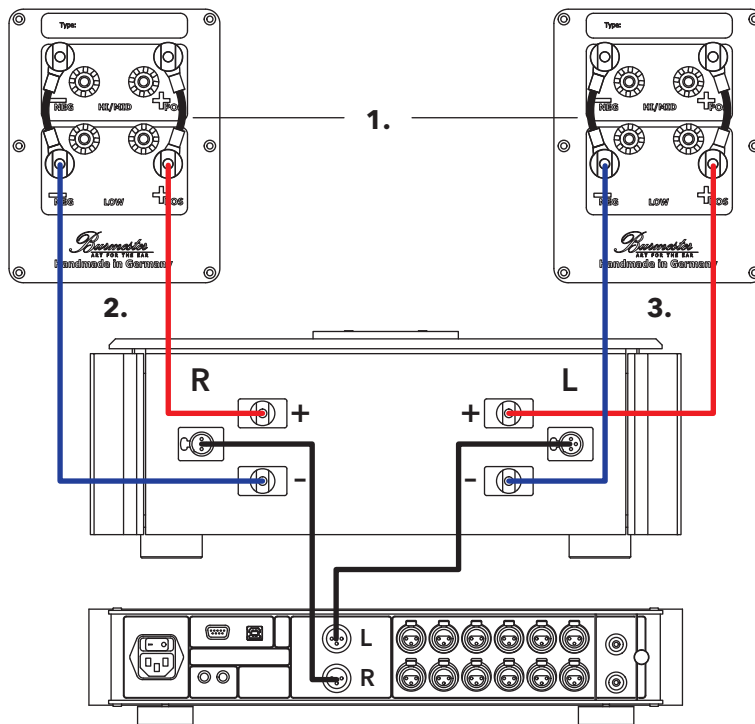

### Connecting the speakers:

1. The speakers are equipped with bi-wiring jumpers on delivery. Make sure that the woofer terminals (LOW) are connected to the tweeter/mid-range terminals (HI/MID) via the jumpers.
2. Connect the left speaker to the left amplifier output.
3. Connect the right speaker to the right amplifier output.

After connecting the speakers, continue by reading „Operating the Loudspeakers“ on page 18.

## 5.5 Bi-wiring connection

Bi-wiring is a means of separately connecting the woofers and mid-range/tweeters of a loudspeaker to one amplifier channel. Stereo reproduction with bi-wiring therefore also only requires one dual-channel (stereo) amplifier. Bi-wiring has acoustic advantages over the classic connection type.

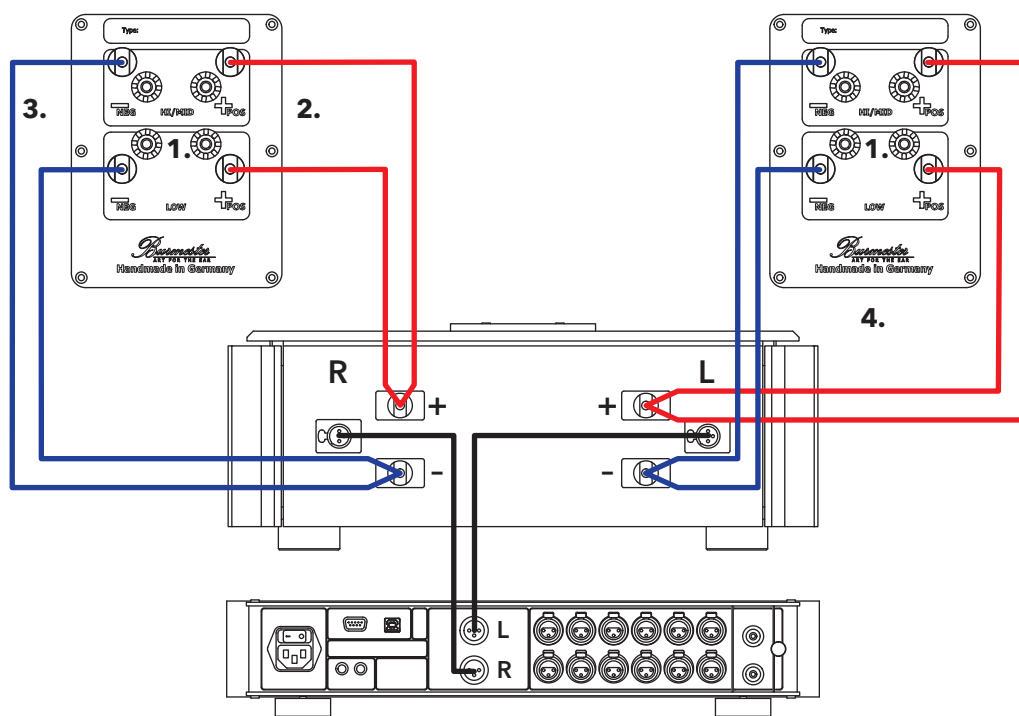

### Connecting the speakers:

#### NOTE:

To connect the loudspeaker to the amplifier, you can use either one 2-wire speaker cable or two 1-wire speaker cables.

1. Remove the bi-wiring jumpers between the woofer terminals (LOW) and the tweeter/mid-range terminals (HI/MID) located above them.
2. Connect the two positive poles (red) on the right speaker to the positive speaker terminal on the right output of the amplifier.
3. Connect the two negative poles (blue) on the right speaker to the negative speaker terminal on the right output of the amplifier.
4. Follow the same procedure to connect the left speaker to the left amplifier output.

After connecting the speakers, continue by reading „Operating the Loudspeakers“ on page 18.

## 5.6 Bi-amping connection

While bi-wiring merely splits the signal paths to the loudspeaker, bi-amping connects both the woofers and mid-range/tweeters to two separate power amplifier channels. Bi-amping provides additional acoustic advantages, since it frees the amplifier channel for the mid-range/tweeter unit from the high power requirements of the woofers. However, this connection type also requires twice as many amplifier channels. Bi-amping can be accomplished in either a vertical or a horizontal arrangement.

### 5.6.1 Vertical bi-amping

When using dual-channel (stereo) amplifiers, a single amplifier is connected to a single speaker in a vertical bi-amping arrangement. One channel is responsible for the woofer unit, the other for the mid-range/tweeter unit. The advantage of this variant is that each of the amplifiers is situated near the speaker and only short speaker cables are required.

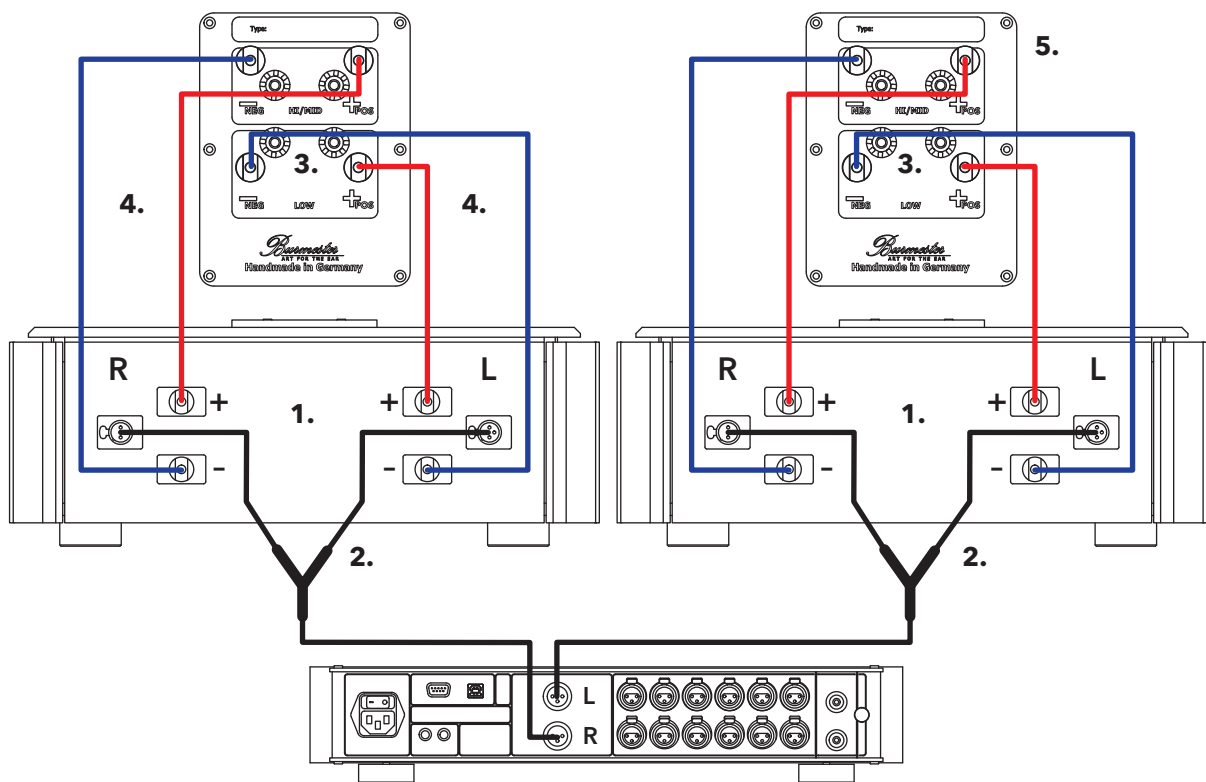

#### Connecting the speakers:

1. Position the two stereo amplifiers near the speakers.
2. Connect the preamplifier to the stereo amplifiers as shown above. You will need two optional Burmester bi-amp adapters or adapter cables. Please contact your specialist dealer for assistance.
3. Remove the bi-wiring jumpers between the woofer terminals (LOW) and the tweeter/mid-range terminals (HI/MID) located above them.
4. Connect the woofer unit on the right speaker to the left amplifier output and the mid-range/tweeter unit to the right output.

#### NOTE:

It is also possible to connect the woofer unit to the right amplifier output and the mid-range/tweeter unit to the left output.

5. Follow the same procedure to connect the left speaker to the second amplifier.

After connecting the speakers, continue by reading „Operating the Loudspeakers“ on page 18.

### 5.6.2 Horizontal bi-amping

When using dual-channel (stereo) amplifiers, in a horizontal bi-amping arrangement, one amplifier is connected to the woofer units and one amplifier to the mid-range/tweeter units on both speakers. The advantage of this variant is that the amplifier for the (acoustically important) mid-range/tweeter unit no longer has to furnish the high power required by the woofer unit. The disadvantage is that this variant requires the same cable lengths as those for the classic connection option and for bi-wiring.

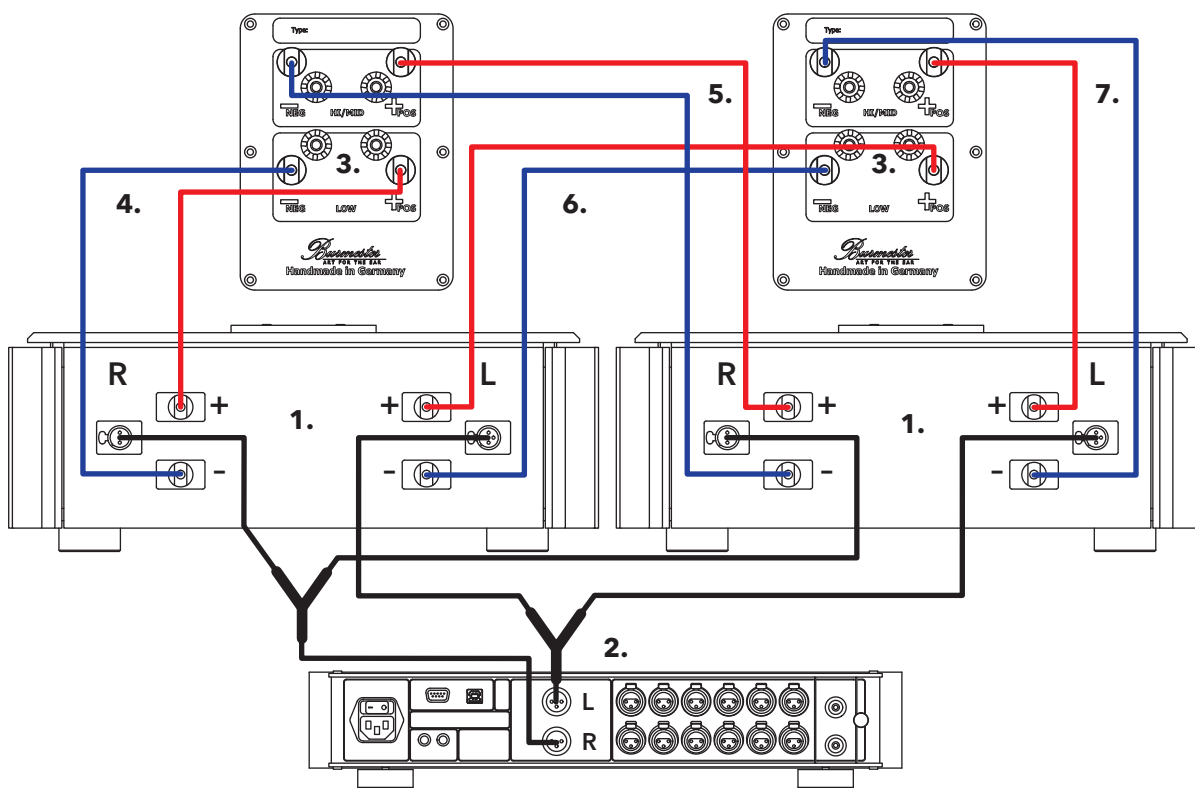

#### Connecting the speakers:

1. Center the two stereo amplifiers between the loudspeakers.
2. Connect the preamplifier to the stereo amplifiers as shown in the diagram. You will need two optional Burmester bi-amp adapters or adapter cables. Please contact your specialist dealer for assistance.
3. On the speaker connector panel, remove the bi-wiring jumpers between the woofer terminals (LOW) and the tweeter/mid-range terminals (HI/MID) located above them.

#### Right speaker:

4. Connect the woofer unit to the right output of the right amplifier.
5. Connect the mid-range/tweeter unit to the right output of the left amplifier.

#### Left speaker:

6. Connect the woofer unit to the left output of the right amplifier.
7. Connect the mid-range/tweeter unit to the left output of the left amplifier.
8. After connecting the speakers, continue by reading „Operating the Loudspeakers“ on page 18.





## 6 OPERATING THE LOUDSPEAKERS

### NOTICE

#### Incorrect wiring or excessive sound levels

Incorrect wiring or excessive sound levels can damage the system components.

- ▶ Before switching on the system, check all cable connections for correct polarity (positive, negative).
- ▶ After re-wiring, slowly increase the volume until you are certain that everything is connected correctly.

#### NOTE:

All chassis in this speaker are burned in and selected as pairs using a digital measuring system. However, like all mechanical systems, the speakers need an initial burn-in period to develop their full acoustic potential.

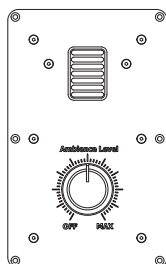

### 6.1 Improving your audio – ambience tweeter

At higher frequencies, loudspeakers emit an increasingly bundled sound field. On conventional loudspeaker systems, this results in very precise, yet sometimes restricted spatial reproduction.

To counteract this effect, the BA31 is equipped with an additional, back-firing tweeter. This ensures a broader stage, with more depth, which you can adjust according to your personal preferences using the continuous level control.

- ▶ Adjust the level of the back-firing tweeter to suit your individual sound preferences. Ideally, a good balance is achieved between spaciousness and the precise reproduction of individual instruments and voices.
- ▶ You can also vary the exact position of the speakers as well as the angle of the speakers to your listening space.

## 7 MAINTENANCE, REPAIR, AND CARE

### NOTICE

#### Damage to the speaker surface

Liquids and chemical agents can damage the housing surface.

- ▶ Make sure that no liquids enter the loudspeaker.
- ▶ Do not use chemical agents to clean the speaker.

## 8 DISPOSAL



Legislation prohibits the disposal of this device by means of normal household waste (residual waste, recycling, organic waste, paper, glass). The device must be handed over to a communal collection point or voluntary take-back system.

## 9 WARRANTY

All Burmester loudspeakers come with a two-year warranty and a three-year warranty extension. The warranty requires proper connection without overloading, the mechanical integrity of the loudspeakers, and **the submission of a warranty claim**.

The warranty does not apply if unauthorized modifications are made, the chassis or terminals are dismantled, or the loudspeakers are opened.

## 10 TROUBLESHOOTING

Malfunction	Probable cause	Remedy
No sound from one or both speakers	Electronics are not switched on	▶ Switch on the amplifier and/or audio source.
	Short circuit or open circuit in wiring	▶ Check the wiring and eliminate any faults.
Poor bass response or diffuse sound quality	Polarity error in the wiring for a channel	▶ Swap the positive and negative wires on the affected channel
Extremely loud and sloppy bass	Speakers are located too close to the walls	▶ Increase the spacing between the speaker and the wall. Increasing the distance to your listening position can also produce an improvement.
Treble range is quieter than normal	Tweeters are not directed toward the listening position	▶ Angle the loudspeaker somewhat more toward the listening position.

## 11 TECHNICAL DATA

Transmission range ( $\pm 3$ dB)	38 Hz – 45 kHz
Rated power	200 W
Efficiency (2.83 V, 1 m)	87 dB
Impedance	4 – 8 ohms
Nominal impedance	4 ohms
Crossover frequencies	400 Hz, 3000 Hz
Dimensions (W x H x D)	253 x 1050 x 375 mm / 10x41.3x14.8 in.
Weight	40.5 kg / 89.4 lbs.

Subject to technical changes

*Burmester*  
A U D I O S Y S T E M E

**BURMESTER HOME AUDIO GMBH**  
Wilhelm-Kabus-Strasse 47  
D-10829 Berlin

Tel. +49 (0) 30 787968 - 0  
Fax +49 (0) 30 787968 - 68  
E-mail: [mail@burmester.de](mailto:mail@burmester.de)  
[www.burmester.de](http://www.burmester.de)