

# THE CLASSIC REFERENCE

Classic Reference

---

		4
		5
1.		5-6
2.		6
3.		6-7
4.		7
5.		8
6.		8
7.		8-9
8.		9
9.	(VTA)	10
10.		10
		11
		12
		13

---

Pro-Ject

,

- 1.
- 2.
- 3.
- 4.
- 5.
- 6.
- 7.
- 8.
- 9.
- 10.
- 11.
- 12.
- 13.
- 14.
- 15.
- 16.
- 17.
- 18.
- 19.
- 20.
- 21.
- 22.
  
- a.
- b.
- c.
- d.
- e.
- f.
- g.
- h.
- i.
- j.
- k.
- l.
- m.
- n.

SME

( 3 )

( 3 )

1,5 ( )

2 ( )

3 (( , (VTA))

78 / .

27 (33), EVOLUTION ( 6,5 - 11 )

26 (32), EVOLUTION ( 9 - 16 )

(CONNECT IT E RCA)

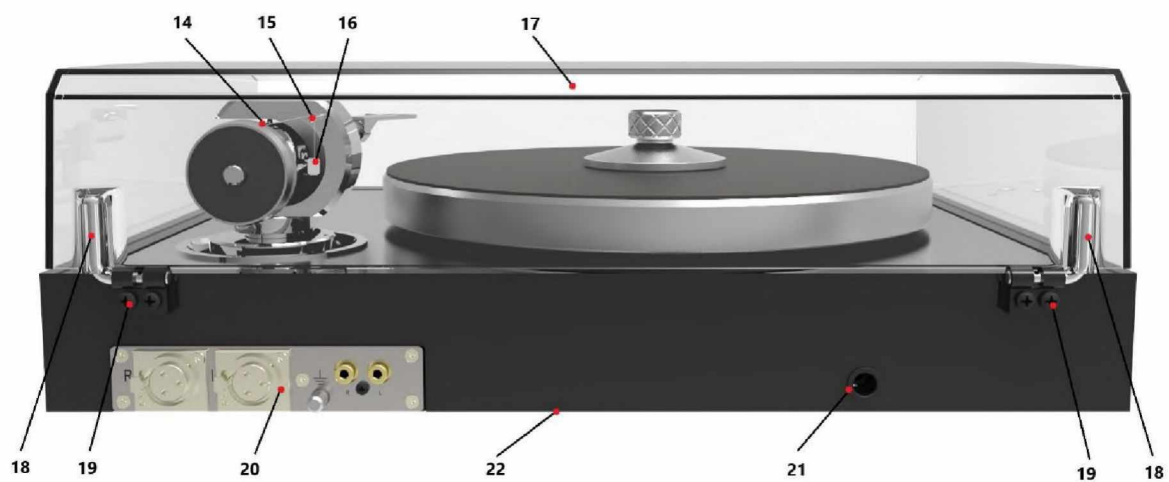
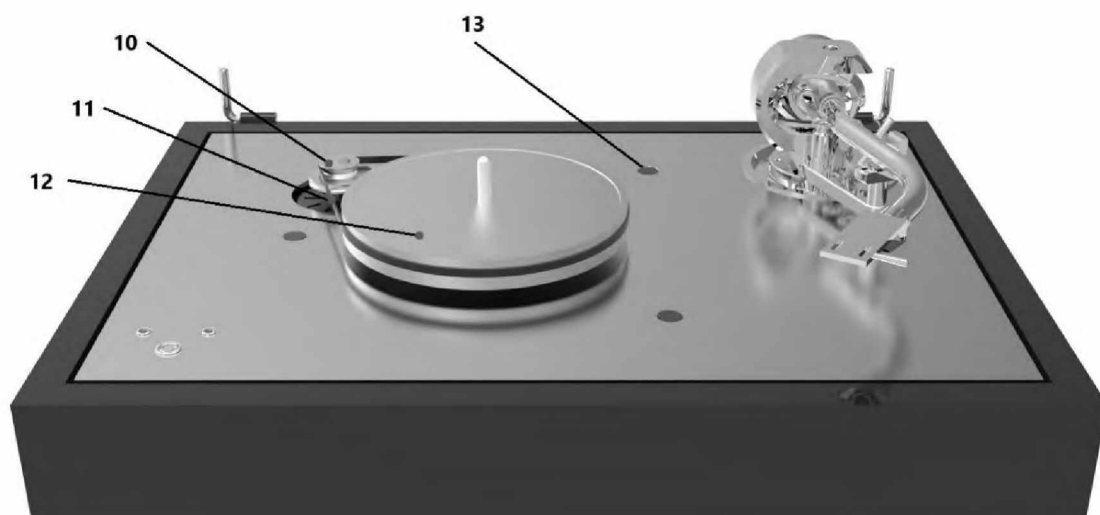

## НАСТРОЙКА

1. \_\_\_\_\_

ОТКРУТИТЕ 3 ТРАНСПОРТИРОВОЧНЫХ ВИНТА

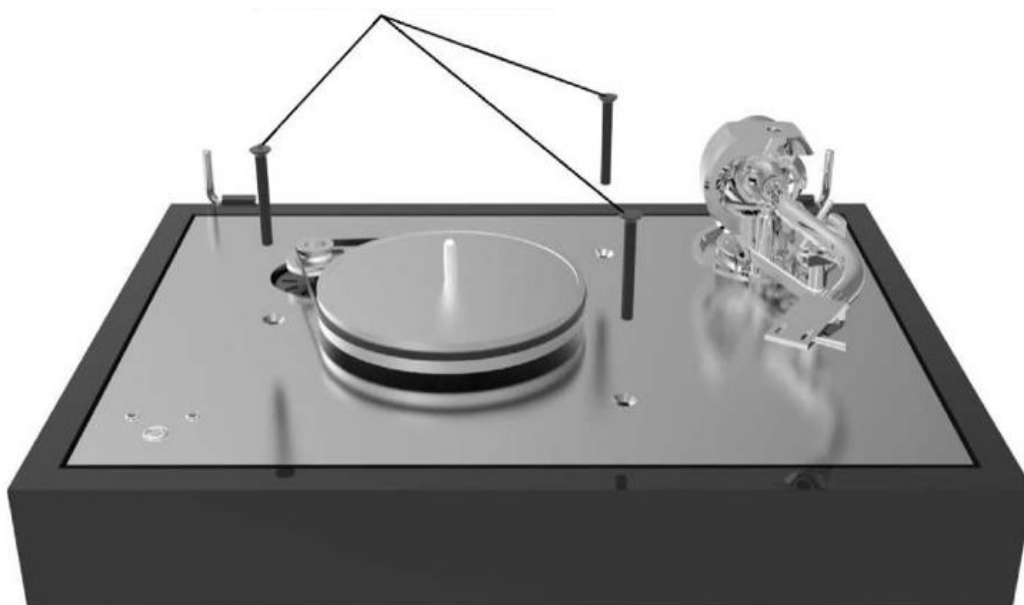

2. \_\_\_\_\_

(11) (12) (10).

(1) (1) (12).

(2)

(21)

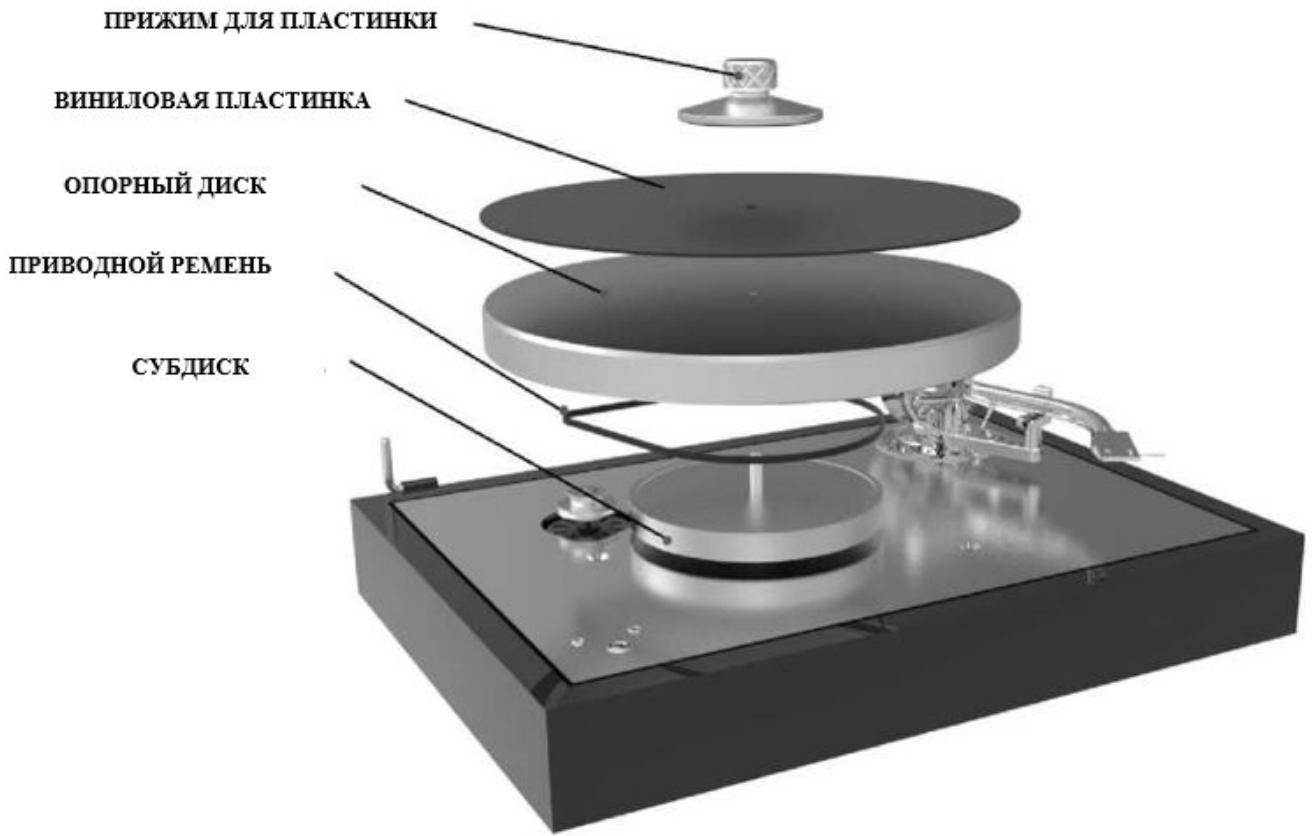

3. \_\_\_\_\_

\*

0,5

- L+
- R+
- R-
- L-

Classic Reference.

4. \_\_\_\_\_

Evolution, 125 )	9 - 16 (	(f, g)	26 (32) -	Evolution, 6,5 - 11 (	27 (33) -
	27	26		142 ).	
	33	32		<b>PIANO / SILVER.</b>	
				<b>ACCACIA / BRASS.</b>	
		(5),		(8)	
		(5)			

(5), (3)

( . )

1 ( 0,1 / 0,1 / )



5. \_\_\_\_\_

\_\_\_\_\_ (15)

10 - 14	1 <sup>st</sup>			
15 - 19	2 <sup>nd</sup>	"	"	"
20	3 <sup>rd</sup>	"	"	"

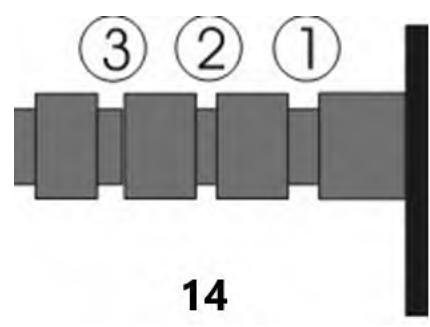

**ШКАЛА РЕГУЛИРОВКИ  
АНТИСКЕЙТИНГА**

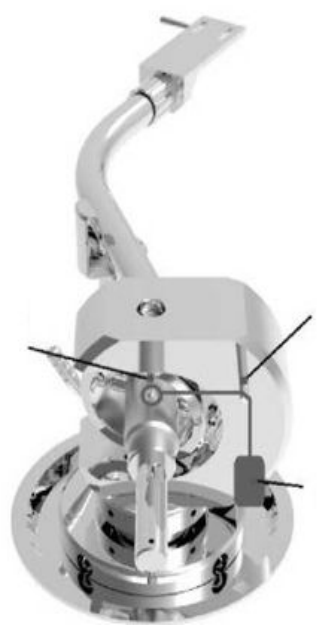

**ПОДДЕРЖКА  
АНТИСКЕЙТИНГА**

**ГРУЗ ДЛЯ ЗАЩИТЫ  
АНТИСКЕЙТИНГА  
НА ПРОВОДЕ**

(14)

(15).

6. \_\_\_\_\_

7. \_\_\_\_\_

33 / ,

(4) —

45 / .

78 / , (10)

(12)  
(1).

78 / .

45 / ,

33rpm LED  
44rpm LED  
Start / Stop  
button

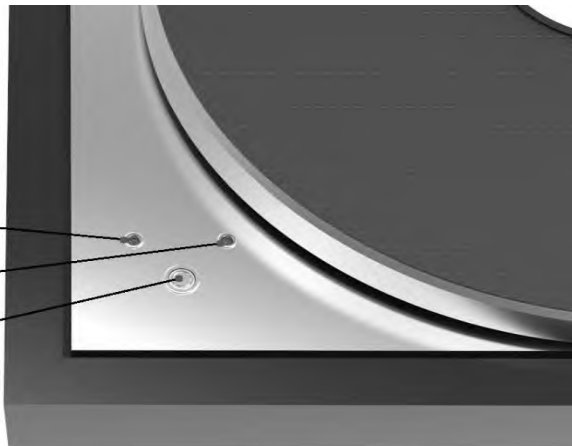

8. \_\_\_\_\_

:

a)  
Phono(Phono

RCA:

gram, disc

RIAA)

RCA/

(CD,

Phono -

b) \_\_\_\_\_ XLR:

XLR

MC.

"True Balanced Connection"



9. \_\_\_\_\_ (VTA)



10. \_\_\_\_\_

ВИНТ РЕГУЛИРОВКИ АЗИМУТА



### Pro-Ject The Classic Reference / Pro-Ject EVO AS 9"

33/45/78 / ,  
33:  $\pm 0.03\%$  45:  $\pm 0.04\%$   
33:  $\pm 0.08\%$  45:  $\pm 0.10\%$   
- 73  
24.2  
9" (230 )  
5  
15 / 0.8 A  
( ) 462 x 138 x 335  
6  
( ) 460 x 131 x 351  
8

Pro-Ject



Pro-Ject Audio Systems i-

Pro-Ject Audio Systems © 2024.

, SEV Litovel, s r.o.  
Palackého 1160/34  
78401 Litovel

( )  
**Pro-Ject Audio Systems** Audio Tuning GmbH  
98,  
1050 ,

( )

:  
2014/35/EU  
2014/30/EU  
2014/53/EU

:

: EN62479:2010  
: EN60950-1:2006+A11:2009+A1:2010+A12:2011+A2:2013,  
EN62368-1:2014/A11:2017,  
EN61558-1:2005/A1:2009, EN61558-2-16:2009/A1:2013  
EMC: EN301489-1 V2.2.0: 2017-03, EN301489-17 V3.2.0:2017-03, EN55032:2015, EN55035:2017,  
EN61000-3-2:2014, EN61000-3-3:2013  
: EN300328 V2.1.1 (2016-11)

**Pro-Ject Audio Systems** Audio Tuning GmbH  
1050 , , , 98  
info@project-audio.com

