

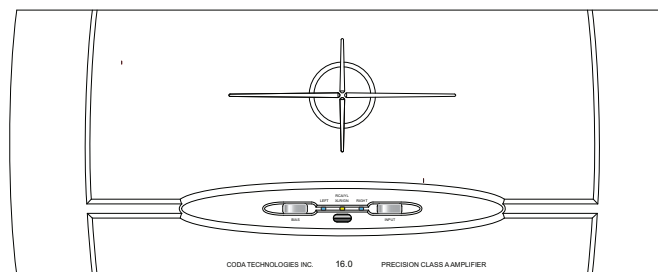

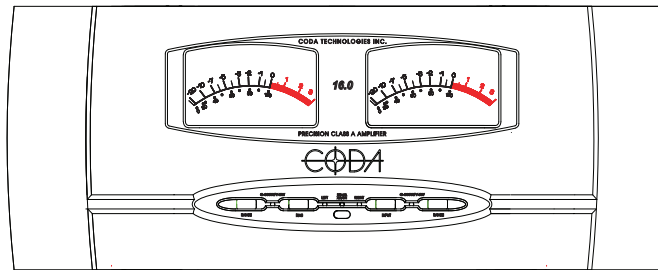

TECHNOLOGIES INC.



SAFETY PRECAUTIONS	1
INTRODUCTION	2
INITIAL SETUP	3
DETAILED INSTALLATION	4
DESIGN PHILOSOPHY	10
TECHNICAL DATA	13
CARE & HANDLING	14
WARRANTY & DISCLAIMER	15
WARRANTY REGISTRATION	16

CAUTION		
	WARNING	
CAUTION: TO PREVENT ELECTRIC SHOCK, DO NOT REMOVE COVER. NO USER SERVICEABLE PARTS INSIDE, REFER SERVICING TO QUALIFIED SERVICE PERSONNEL.		
	THIS SYMBOL IS TO ALERT YOU OF THE PRESENCE OF UNINSULATED DANGEROUS VOLTAGE WITHIN THE UNIT'S ENCLOSURE THAT MAY BE OF SUFFICIENT MAGNITUDE TO CONSTITUTE A RISK OF ELECTRIC SHOCK.	
	THIS SYMBOL IS INTENDED TO ALERT YOU OF THE PRESENCE OF IMPORTANT OPERATING AND MAINTENANCE INSTRUCTIONS IN THE LITERATURE ACCOMPANYING THE UNIT.	

WARNING: TO PREVENT FIRE OR SHOCK HAZARD, DO NOT EXPOSE THIS UNIT TO RAIN OR MOISTURE. TO AVOID ELECTRICAL SHOCK, DO NOT OPEN THE UNIT. REFER SERVICING TO QUALIFIED PERSONNEL.

- CAUTION**
- Never install or remove the power cord from the chassis unless it has been disconnected from the AC power source first.
 - Never pull on the power cord when removing it from an AC power source. Grasp it by the plug.
 - Do not leave the power cord connected to an AC power source unless it is connected to the unit.
 - It is recommend that during extended periods of non-use that the units power cord be unplugged from its AC power source.
 - Route the AC power cord so that it will not be damaged or walked on.

Thank you for purchasing the AMPLIFIER 16.0.

This amplifier is a precision device, designed in an effort to provide the listener with unmatched sound quality through superb design and construction.

Although its operation is fairly simple, in order to operate your amplifier properly and to realize all of the capabilities of the amplifier we recommend that you read this entire manual carefully.

WARNING: Please ensure that the power switch is turned OFF while you are connecting the amplifier. Connecting or disconnecting cables while the amplifier is powered on could cause damage to your speakers.

The diagram below shows the default connections necessary to operate the 16.0 as a stereo amplifier. This is the simplest and most common mode of operation, and the quickest way to get started. Once these connections are made you can turn the power switch on, enable the bias from the front panel and start listening to your amplifier.

For simplicity this diagram shows an audio configuration using balanced interconnects. This is the default input mode of the amplifier. Unbalanced operation requires that you set the appropriate input mode as detailed on page 5.

NOTE: Ensure that the mode switch located between the input jacks on the rear of the amplifier is set to the stereo position for normal operation. Bridged operation is explained on page 7.

Stereo Amplifier Configuration

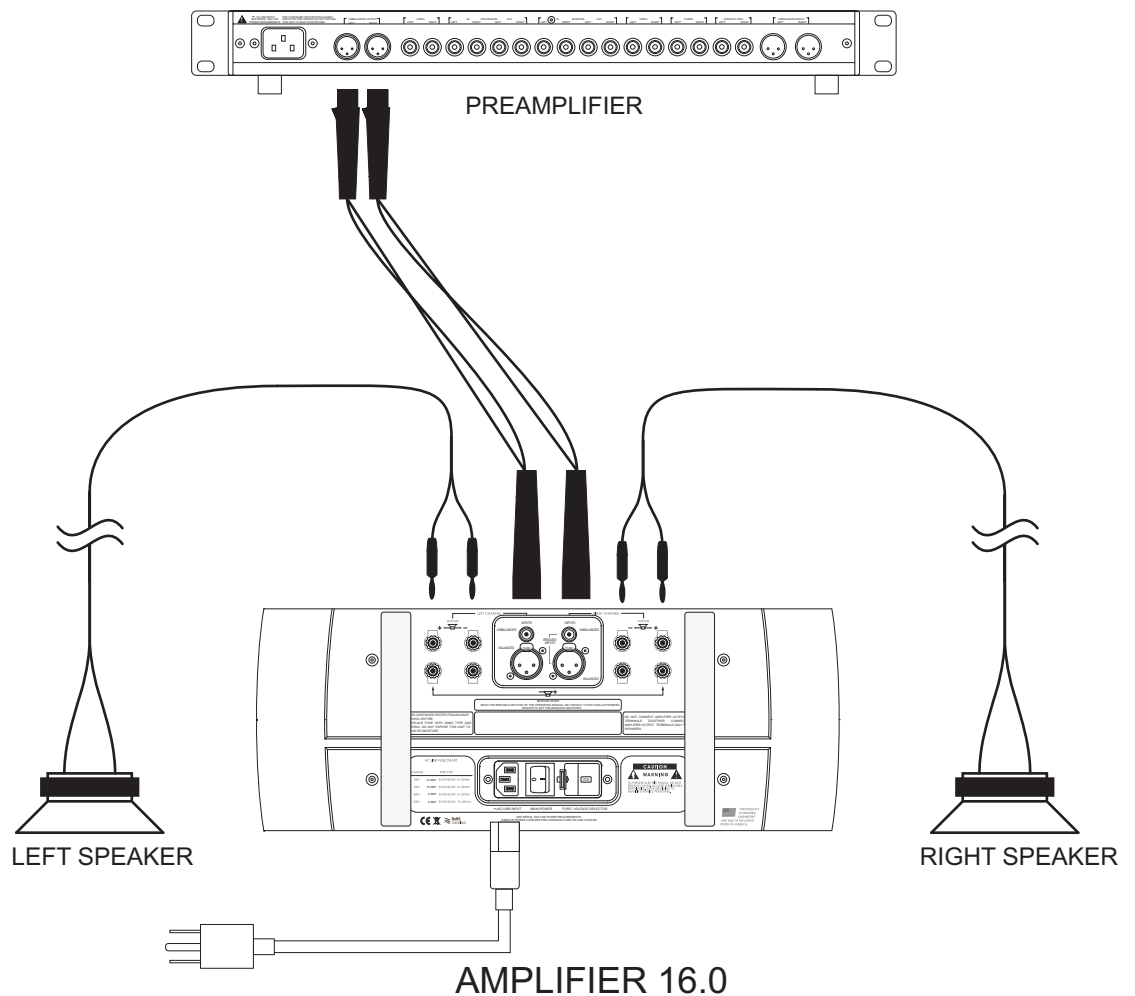

I. Connections

The connectors and controls are clearly marked on the back panel of the amplifier. Note the correct left or right channel orientation. The function and channel markings on the rear panel correspond to the from panel controls and their signal paths.

1. The unbalanced and balanced inputs should be attached to the appropriate unbalanced and balanced outputs of a preamplifier either directly or through a crossover or processor, as appropriate to the application.

2. The left output and right output should be attached to the left and right speakers respectively.

WARNING: Please ensure that the power switch is turned OFF while you are connecting the amplifier. Connecting or disconnecting cables while the amplifier is powered on could cause damage to your speakers.

3. The AC line input should be connected to an AC outlet with the power cable provided with the amplifier.

4. The fuse and voltage selector unit houses a 5x20mm slow-blow fuse and a voltage selector cartridge. Ensure that the voltage, visible through a small window next to the AC input, is set to the appropriate voltage for your country. When changing voltages, ensure that the power cable is disconnected from the amplifier.

NOTE: If the fuse in your amplifier blows, contact a Coda dealer or call Coda directly before attempting to use the amplifier again.

5. The power switch can usually be left on when the amplifier is functioning correctly. With the bias disabled the amplifier will draw negligible current and can thus be left in “standby” indefinitely.

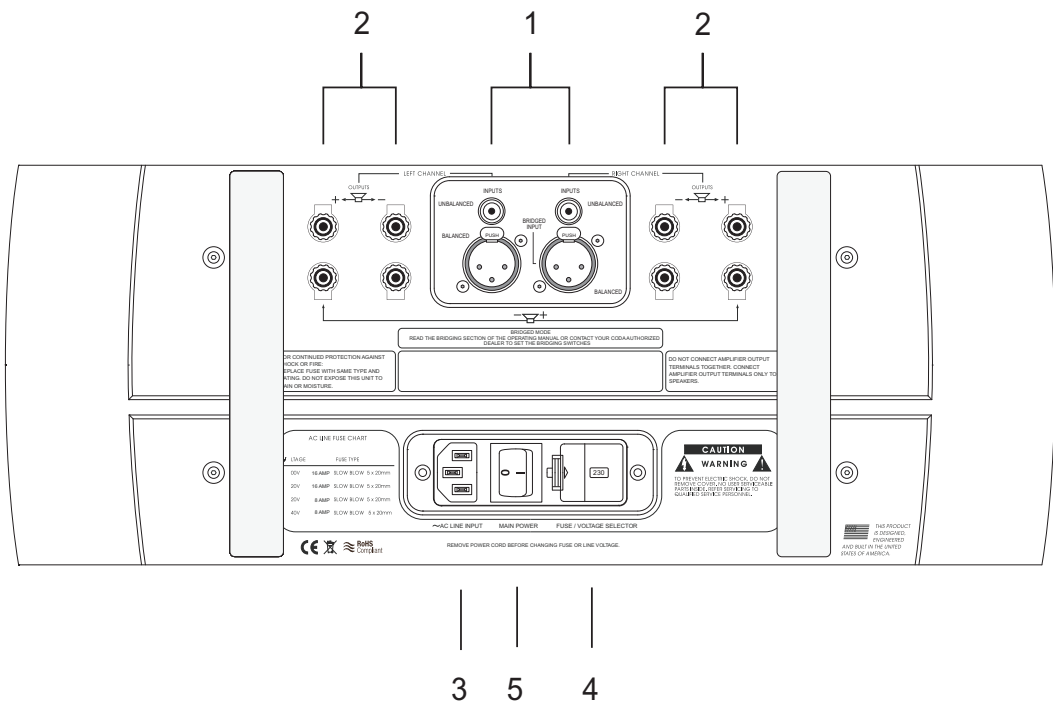

II. Front Panel Control Functions and Indicators

1. The bias button enables the bias, effectively “turning on” the amplifier’s components, and opens shunting relays that mute the input.
2. The input selector button switches between the balanced and unbalanced inputs.
3. These LEDs, when lit, indicate that the bias is enabled and muting is off.
4. This two color LED indicates that the main power is on. When it is green the balanced inputs are in use. When it is yellow the unbalanced inputs are in use.

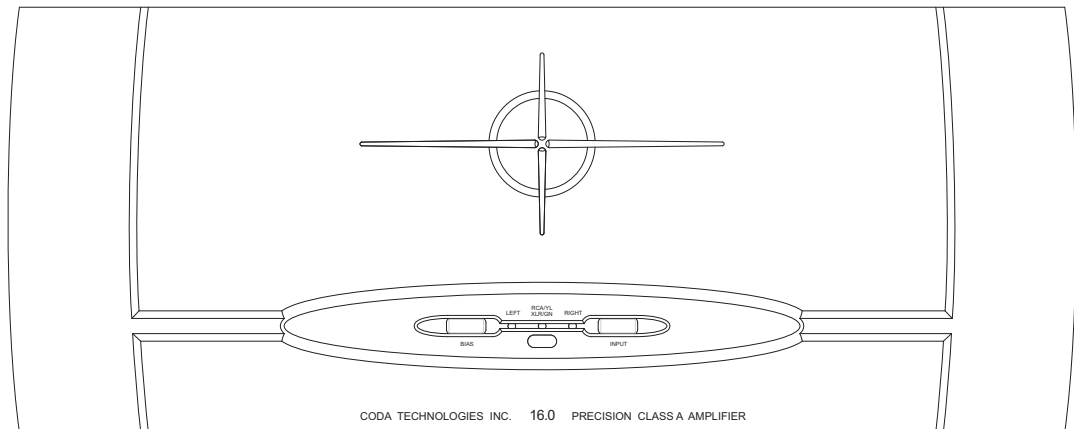

Note: If a power interruption occurs to the system the amplifier will power on with the bias off. Press the bias button to resume use of the amplifier.

III. BRIDGED SETUP

WARNING: Disconnect the amplifier’s power cord from the AC supply and set the power switch to OFF before adjusting the mode switch or connecting or disconnecting any cables to avoid potential damage to your speakers and personal injury due to high internal voltages.

The 16.0 normally operates in stereo mode, providing a maximum output power of 150 watts Class AB (into an 8-ohm load) per channel. In bridged mode, both channels act as one amplifier providing a maximum output power 600 watts. For extremely high-power multi-channel audio applications, multiple 16.0 amplifiers can be used in place of one stereo amplifier.

To configure the amplifier for bridged mode operation you must enable the bridging switches inside the amplifier. Use a 5/64” hex driver to remove the twelve screws from the top of the amplifier and remove the top cover. The bridging switches are mounted on a circuit board attached to the audio input jacks inside the amplifier. The diagram below shows the circuit board. The red slide switches below the arrows are the bridging switches. The arrows show the direction to set the switches to enable bridging. Reverse the switch positions to enable normal stereo operation.

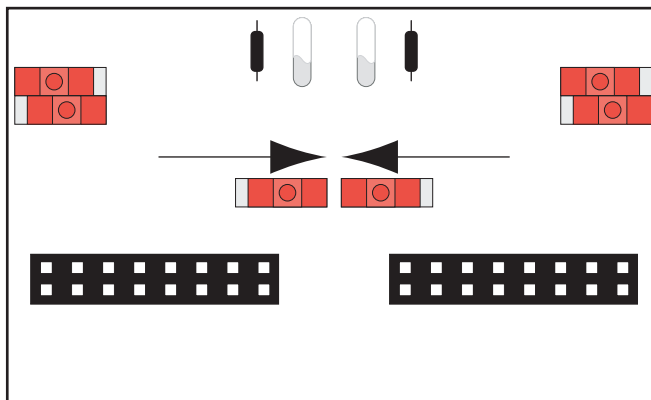

In bridged mode only one audio input is used. No other input should be connected, and the bridged mode input must be a balanced signal connected to the XLR receptacle labeled BRIDGED INPUT. Bridged mode will not operate correctly with an input adapted from an unbalanced signal. Connecting the input signal to the receptacle not labeled BRIDGED INPUT will cause no damage, but will cause the speaker terminal polarities to reverse, with the terminal labeled positive becoming ground and the terminal labeled ground becoming positive.

The amplifier’s speaker terminals are reconfigured in bridge mode. The left channel positive terminal becomes the monaural negative terminal and the right channel positive terminal becomes the monaural positive terminal.

See the next page for a diagram of a stereo amplifier configuration using two bridged mode 16.0 amplifiers. Speaker terminals in the diagram are marked with their bridged mode polarities.

IV. BRIDGED SETUP DIAGRAM

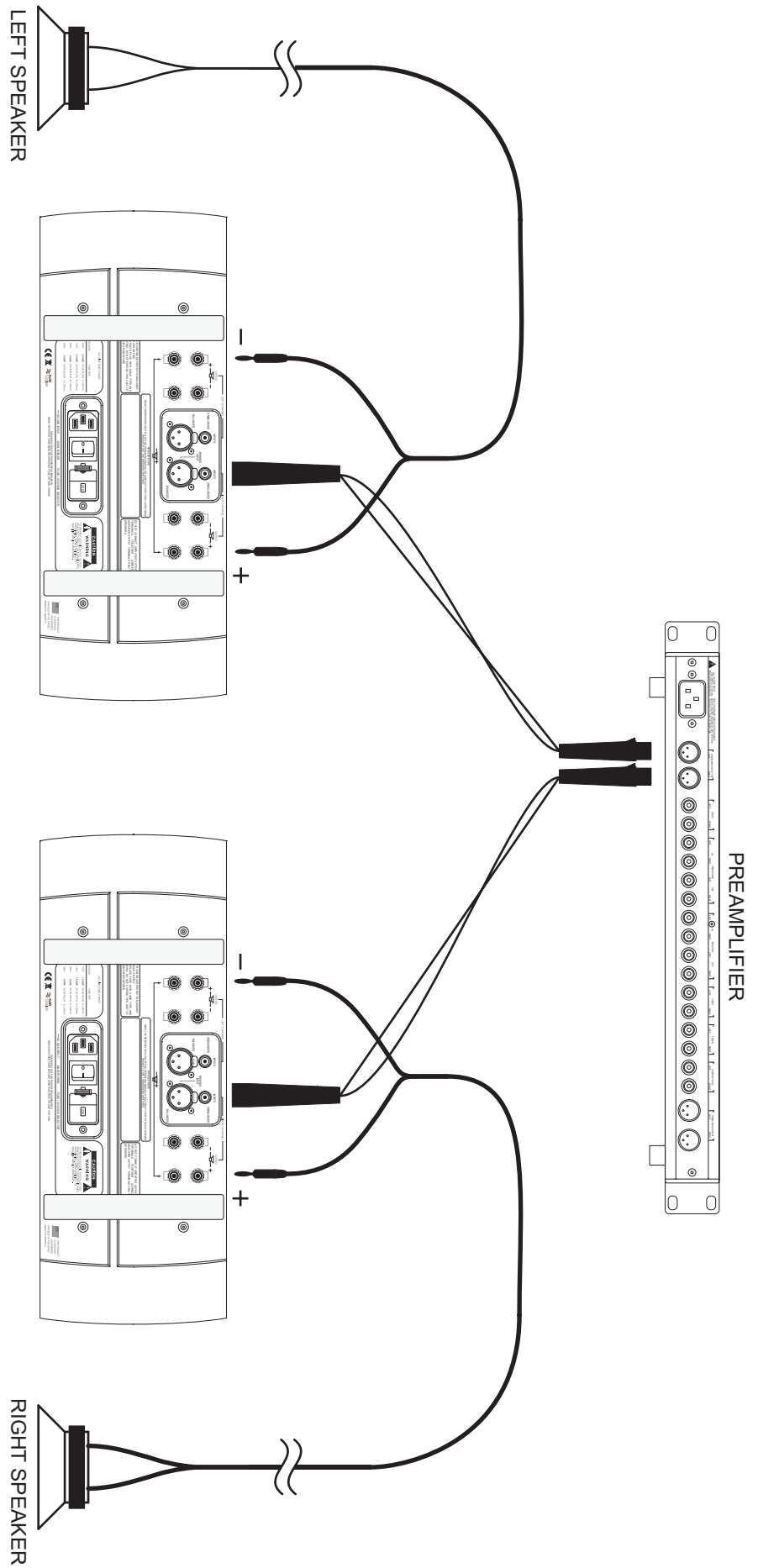

REMOTE OPERATION

The 16.0 can be operated by remote control. The MX-450 Learning Remote is optional. For instructions on using the MX-450 itself see the on screen manual included in the remote.



LOGO LIGHT CONTROL

WARNING: Disconnect the amplifier’s power cord from the AC supply and set the power switch to OFF before making any internal adjustments to avoid personal injury due to high internal voltages.

The light behind the logo on the front panel of your amplifier can be enabled and disabled by setting internal switches inside the amplifier’s chassis. Changing this setting requires removing the amplifier’s top cover.

The light is controlled by two small switches with red sliders located on the PCB attached to the back side of the faceplate. Viewing from the rear of the amplifier, with the cover removed, the switches will be at the top of the PCB as shown below.

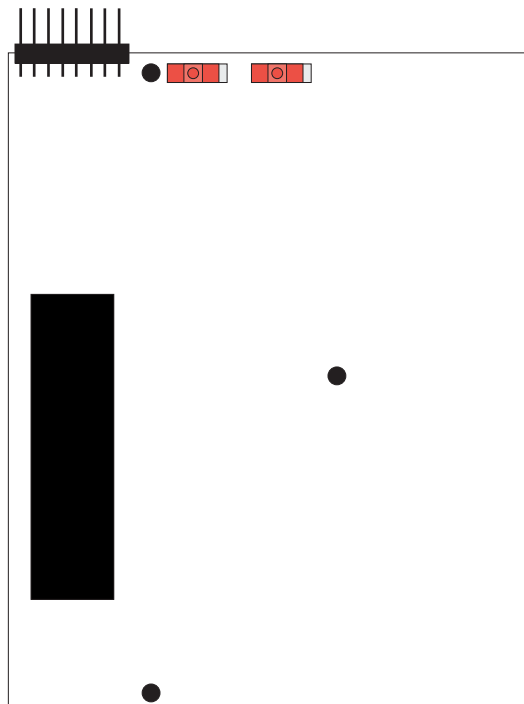

To enable the light only when the bias is turned on:
Slide the left switch to the left or right, and the right switch to the left.

To enable the light at all times:
Slide the left switch to the left, and the right switch to the right.

To disable the light at all times:
Slide the left switch to the right, and the right switch to the right.

I. Design Philosophy and Approach

The subtlety of the design process at this level of performance makes it impossible to easily explain all of the advantages inherent in the 16.0. However, we present here an overview to give you an understanding of some of its unique features and an idea of the listening experience you can expect. Often a particular technique has numerous unrelated advantages and possibilities. We make every effort to exploit these advantages with the final result being an amplifier that performs better than the sum of its individual features suggest.

The topology and component selection is built on the foundation established by the Coda System 100. Balanced interconnections are provided to take advantage of their greater noise rejection. Differential voltage gain throughout provides exceptional rejection of external noise and contributes to the inherent DC stability of the circuit. This allows direct coupling without servo circuitry. The unit also uses output followers operating without feedback.

Excellent high frequency design ensures linear operation at high speed, and translates into a sonic reproduction which is extremely transparent in character. The power supply takes a very direct approach to high performance. First, top quality toroidal transformers and over 280,000 uF of capacitance with very low ESR and inductance are used. For optimum performance and reliability all circuitry remains continuously powered.

The specifications are consistent with what would be expected in a high current amplifier design. In this design, however, an unusual degree of attention has been paid to sonically meaningful parameters.

For example, the current stage is capable of producing peak currents in excess of 100 Amperes with a degree of linearity and speed unmatched by other designs producing only a fraction of this current. This is achieved by the implementation of several distinct circuit features.

Extremely wide bandwidth transistors are used in the output stage instead of the usual TO3 devices used in other output designs. Each channel uses 28 individual output transistors with a combined power rating of 1500 Watts and 120 Amperes with a bandwidth of 50 Mhz.

The 16.0 uses bias voltages and component values which have been specifically selected to produce a precision transition with no abrupt changes in distortion or output impedance. This "Precision Bias" technique yields seamless performance regardless of the complexity of the load impedance and is particularly effective at eliminating IM distortion which often occurs in these instances.

I. Design Philosophy and Approach (continued)

To maintain "Precision Bias" requires an advanced bias circuit that must have a very high degree of stability under a wide range of temperatures and load conditions. Most amplifier bias networks are of such high impedance and poor thermal regulation that at the extremes of operation, bias currents are ineffectively controlled. Advanced tracking techniques used in the 16.0 result in absolute control of bias currents under all conditions.

The main power supply of the amplifier consists of a 3000VA transformer with independent rectifiers to isolate the channels from one another. 280,000 uF of total capacitance provide effective filtering of all AC ripple.

These attributes result in an amplifier of such extreme linearity and bandwidth that no overall feedback correction is required or used. One advantage of this is a high degree of immunity from interactions with loads or cables and a superior transient response. An extremely low nonreactive output impedance is maintained well beyond 20,000Hz. the resulting uniform damping factor is not commonly found in other designs.

The chassis of the 16.0 is constructed of machined aluminum milled to very close tolerances yielding the seamless appearance characteristic of previous products from Coda. As with all high-power amplifiers, heat dissipation is important. The 16.0 uses six massive aluminum heat sinks without fans for efficient, noiseless and clean thermal relief. The thermal coefficient of the 16.0 heat sinks is one of the lowest and most effective in the audio industry.

II. Material Quality

The amplifier's chassis is made from machined aluminum. All exterior metal parts are anodized or powder coated for durability.

Printed circuit boards are fiberglass epoxy with gold plating over a tin/nickel barrier. The gold layer will not corrode, while the barrier layer prevents the gold from migrating to the lower copper layer.

All resistors are precision metal film; 1% tolerance for 1/4-watt and 5% tolerance for 1-watt.

Capacitors have been eliminated wherever possible. No electrolytic capacitors are used except in the power supply, where several high-capacitance electrolytics provide outstanding filtering of the supply output.

All semiconductor devices are of very high grade. Voltage gain is accomplished with an extremely high-quality, matched dual FET, chosen for its exceptionally low noise characteristics.

All audio input and output connector contacts are gold-plated, and XLR receptacles are manufactured by Neutrik of Switzerland. Wire is used as little as possible in the signal path - only to connect the RCA jacks and speaker terminals to the circuit board - and what is used is 141-strand silver-plated copper with silicone insulation.

STEREO

Rated Power:	150 Watts class AB (100 Watts class A) @ 8 Ohms, 300 Watts class AB @ 4 Ohms
Frequency Response:	DC to -3dB @ 100kHz
Distortion:	< .02 percent from 10Hz to 20kHz @ rated power
Gain:	26dB
Maximum Current:	>100 Amperes peak per channel
Noise:	-120dB referenced to rated output
Input Impedance:	50k Ohms unbalanced/10k Ohms balanced
Output Impedance:	.03 Ohms from 20Hz to 20kHz

BRIDGED MONO

Rated Power:	600 Watts class AB @ 8 Ohms 1200 Watts class AB @ 4 Ohms
Frequency Response:	DC to -3dB @ 100kHz
Distortion:	< .02 percent from 10 Hz to 20kHz @ rated power
Gain:	32dB
Maximum Current:	>100 Amperes peak
Noise:	-130dB referenced to rated output
Input Impedance:	N/A unbalanced/10k Ohms balanced
Output Impedance:	.06 Ohms from 20Hz to 20kHz

POWER SUPPLY

Transformer Type:	Multi-tap, multi-winding toroidal
Transformer Rating:	3 kVA
Power Filtering:	280,000 μ F

DIMENSIONS

Height:	7" Faceplate, 7.75" Overall
Width:	18" Overall
Depth:	19" Overall
Weight:	110 lbs., 115 lbs. Shipping
Power requirement:	1K Watts maximum at rated power

The interior of the unit requires no special care. If it becomes necessary to clean the exterior, a simple dusting may be all that is required. If a cleaner is necessary, any dilute commercial ammonia based product will be appropriate. NEVER use any abrasive rags, cleaners or chemical solvents on Coda products.

When handling the unit, take care not to mar the aluminum. Aluminum is a medium hardness metal and can be scratched by the harder tool steels.

Avoid exposing the unit to direct sunlight, and keep it away from sources of intense heat.

Do not throw away the carton or associated packing material. They are ideal if you need to pack the unit for moving and in the unlikely event that servicing is needed, they will be necessary for safe shipment.

Be sure to provide adequate insurance when shipping.

I. Warranty - Any failure of the amplifier, hereafter known as the product or original product, to operate or to meet specifications, applicable at time of manufacture, due to a manufacturing defect or component failure, will be corrected by Coda Technologies without charge for parts or labor, for a period of ten years from date of original purchase. Coda Technologies will provide for surface transportation to and from the factory for a period of one year from date of original purchase.

II. Procedure - If the product should require service under warranty contact Coda Technologies at the location on the back cover of this manual for shipping instructions. Products purchased outside of the United States will be covered by the warranty conditions extended by the importing distributor which may differ from those given above.

III. Exclusion of Coverage - Coda Technologies is not obligated to service the product in certain conditions, as according to the following subsections.

a. The product has been damaged through:

- i. operation not in accordance with the instructions in this manual
- ii. abuse, tampering, modification or accident
- iii. serial number defacement

B. The product has been transferred to a third party. In this case the warranty is valid for 5 years from date of manufacture as determined from the serial number

c. The product has been transported outside of the United States of America.

In these conditions any service will be made at Coda Technologies sole option.

IV. Total Loss and Replacement - If the product is submitted for service due to a severe malfunction which has caused damage sufficient enough to make a repair attempt infeasible, the product will be replaced with another unit of equal or superior specifications. Coda Technologies product line is frequently updated and changed, and the specific model and version of the original product may be discontinued at any time without notice. In this case no guarantees are made that the replacement unit will be visually similar to the original product.

V. Subjective Differences - No guarantee is made that the product will perform to any specifications that cannot be measured and confirmed with precision audio analysis equipment. Coda Technologies is only obligated to make repairs which will bring the product into compliance with the specifications stated in this manual.

VI. Unnecessary Service - In all conditions, if the product is submitted for service and found to be operated without fault and within specifications, shipping charges will be billed to the customer.

This warranty gives you specific legal rights. You may have other rights which vary from state to state.

Disclaimer - Coda Technologies cannot be held responsible for any damage caused by their products, including but not limited to:

- a. Damage to speakers caused by failure of a Coda Technologies product to mute or disable itself as expected or described in its manual.
- b. Damage caused by connecting a load to a Coda Technologies product having an improper impedance as described in the products manual.
- c. Damage caused by defects in design, construction or component quality.

Fill in this registration sheet and fax or mail it to Coda Technologies to ensure you are in our warranty system. This will facilitate warranty service should it become necessary.

It is recommended that you retain a copy of this form for your own records. Coda Technologies' address and fax number are located on the back of this manual.

MODEL DESIGNATION: _____

SERIAL NUMBER: _____

DATE OF PURCHASE: _____

PLACE OF PURCHASE

Name: _____

Address: _____

City: _____ State: _____ Zip: _____

Phone: _____

OWNER INFORMATION

Name: _____

Address: _____

City: _____ State: _____ Zip: _____

Phone: _____

NOTES:

Fill in this registration sheet and fax or mail it to Coda Technologies to ensure you are in our warranty system. This will facilitate warranty service should it become necessary.

It is recommended that you retain a copy of this form for your own records. Coda Technologies' address and fax number are located on the back of this manual.

MODEL DESIGNATION: _____

SERIAL NUMBER: _____

DATE OF PURCHASE: _____

PLACE OF PURCHASE

Name: _____

Address: _____

City: _____ State: _____ Zip: _____

Phone: _____

OWNER INFORMATION

Name: _____

Address: _____

City: _____ State: _____ Zip: _____

Phone: _____

NOTES:

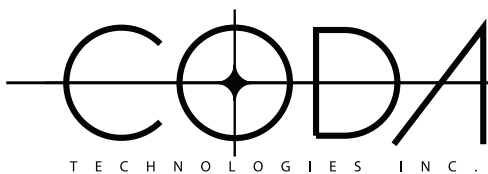

7850 CUCAMONGA AVENUE #34
SACRAMENTO, CA 95826 USA

phone [+01 916.383.3653](tel:+19163833653) fax [+01 916.455.3653](tel:+19164553653)
on the web at CODA.CC
email us at info@codacc.com