



INSTRUCTIONS FOR USE
Pro-Ject T2 Super Phono

Dear Music Lover,

Congratulations and thank you for choosing Pro-Ject Audio Systems record player.

Your T2 Super Phono turntable has been handcrafted and rigorously tested by skilled technicians to give you years of enjoyable, trouble-free service.

If you require additional assistance, please contact your dealer.

Important:

Your turntable was shipped partially disassembled to avoid damage to sensitive parts. Please check immediately to ensure that neither the packaging nor the device was damaged in transit. If you are missing parts or if the unit is damaged, please do not operate it and contact your dealer.

Contents

Product illustrations 4

Setup

- 1. Platter and drive belt installation 5
- 2. Cartridge installation, stylus exchange 5
- 3. Vertical Tracking Force setting (VTF) 6
- 4. Maintenance and cleaning 7
- 5. Switching ON and OFF, changing replay speed 7
- 6. Anti-skating 7
- 7. Connection to the amplifier 8

Technical parameters 9

Troubleshooting, warranty, service 10

Exploded view of the packaging 12

Please do your part to help protect the environment:

Disposal of packaging material:

Pro-Ject packaging is carefully designed to protect your component from damage during transit, and you are strongly urged to keep the original packaging to safely ship or otherwise transport your turntable in the future. However, the packaging materials were chosen to be environmentally friendly, so if you must discard the packaging, please recycle it.

GENERAL INFORMATION

Controls, features and connections

- 1 PLATTER & FELT MAT
- 2 CHASSIS
- 3 SPEED CONTROL BUTTON
- 4 MOTOR WITH PULLEY
- 5 DRIVE BELT
- 6 SUB-PLATTER
- 7 TONEARM COUNTERWEIGHT
- 8 ANTI-SKATING ADJUSTMENT SCREW WITH SCALE
- 9 TONEARM REST / REMOVABLE TRANSPORT LOCK
- 10 TONEARM LIFT LEVER
- 11 TONEARM TUBE
- 12 HEADSHELL WITH FINGER LIFT AND PRE-MOUNTED CARTRIDGE
- 13 LID
- 14 LID HINGES
- 15 HINGE FASTENERS
- 16 POWER SUPPLY SOCKET
- 17 RCA OUTPUT BOX
- 18 PHONO / LINE SWITCH

Accessories

- 1 SINGLE ADAPTOR
- 2 ALLEN KEY 1,5mm
- 3 COUNTERWEIGHT no. 105 (FOR CARTRIDGE WEIGHT 5 – 11.5g)
- 4 TWO-POINT CARTRIDGE ALIGNMENT PROTRACTOR
- 5 CONNECTION CABLE (CONNECT IT E RCA)
- 6 SETUP GUIDE
- 7 UNIVERSAL POWER SUPPLY

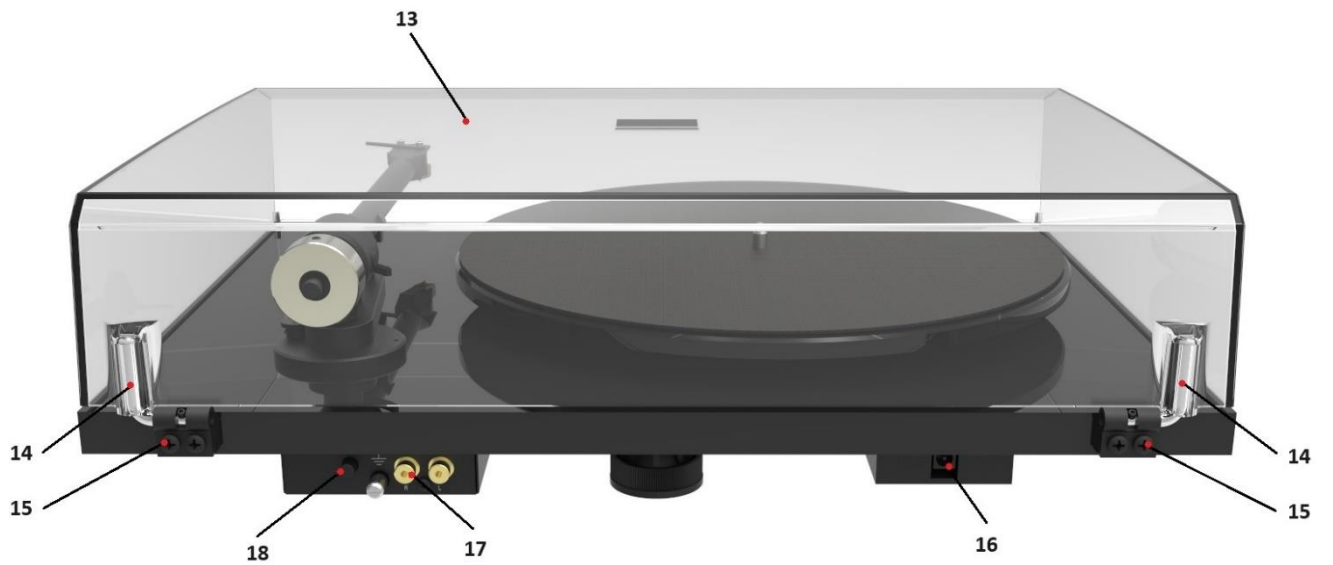
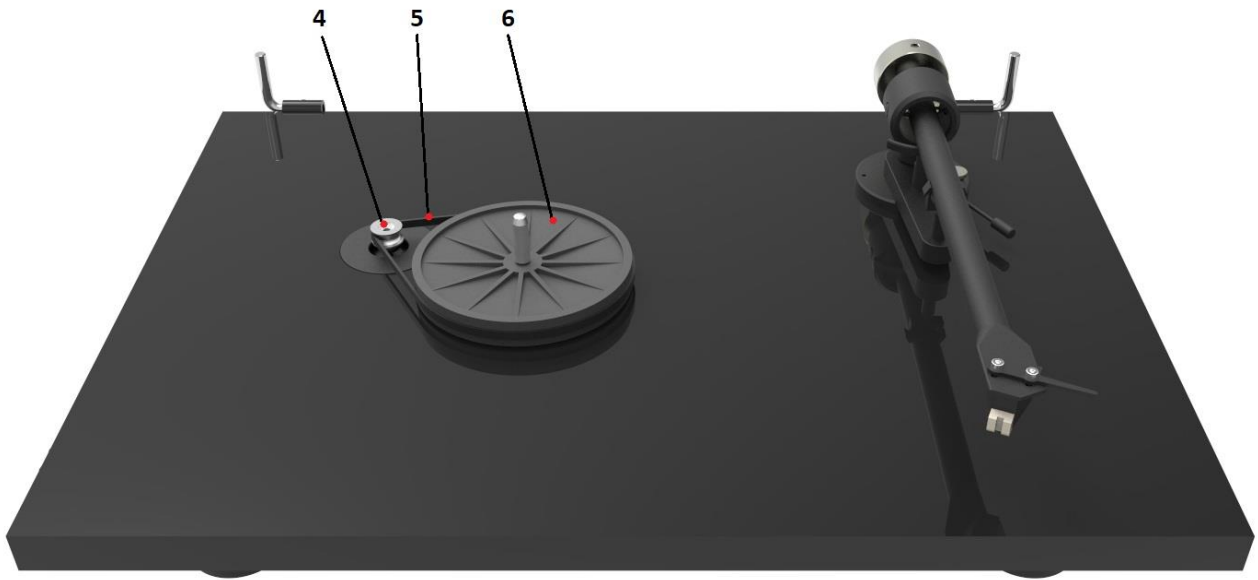
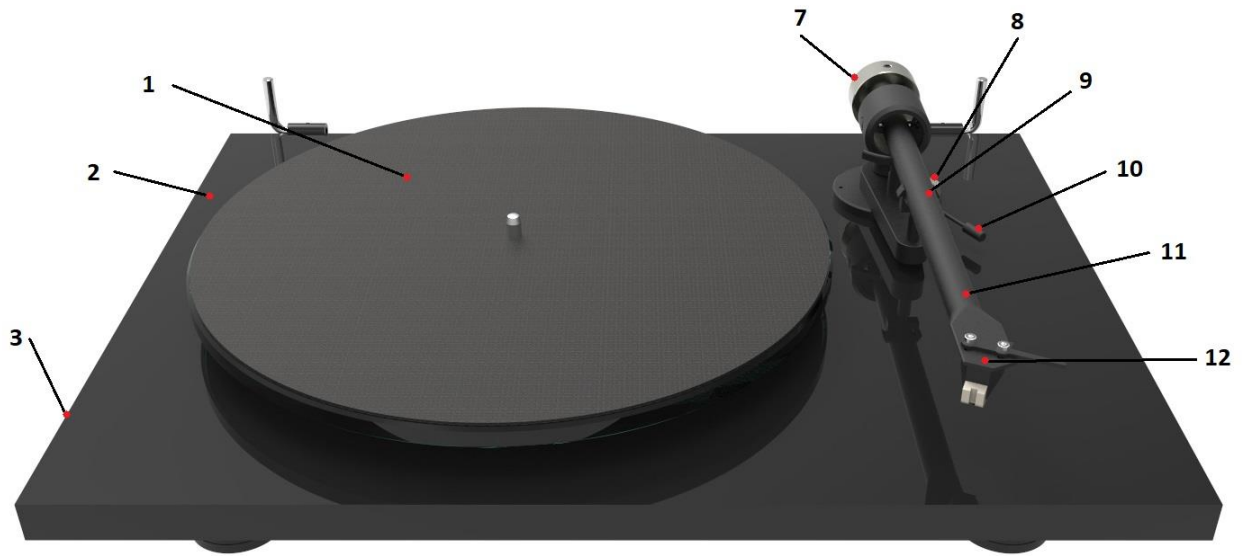

SETUP

1. Platter and drive belt installation

Please remove drive belt from accessories box and install it as shown in the following illustration. Put the felt mat on the top of the platter.

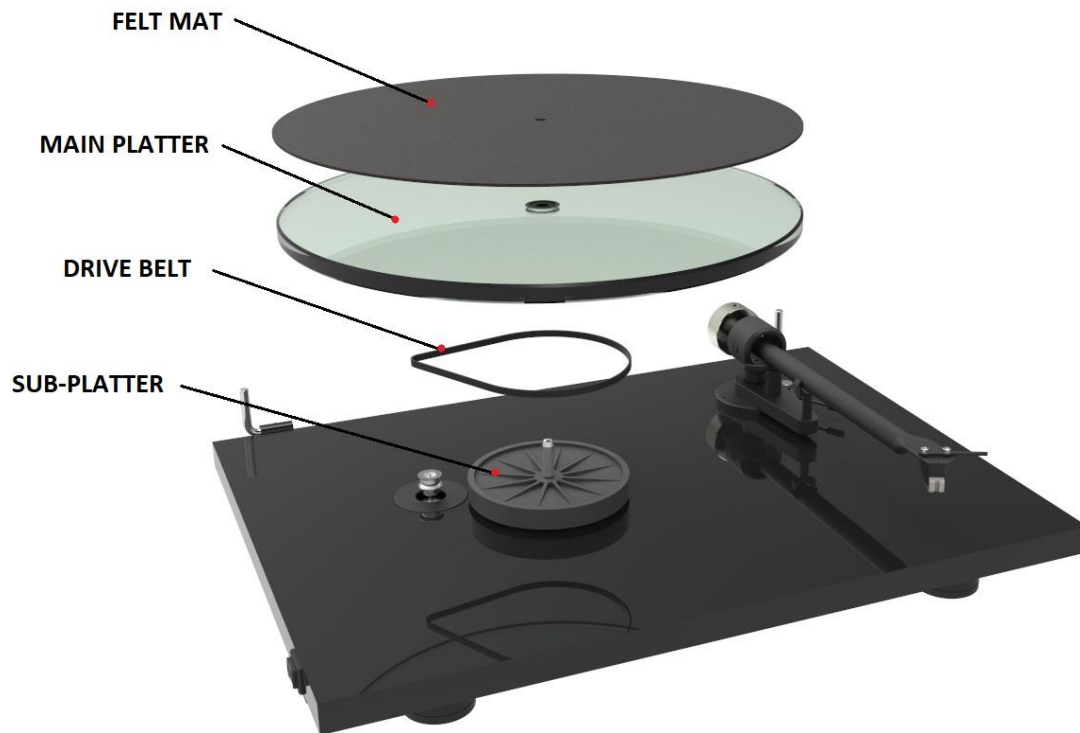

2. Cartridge installation, stylus exchange

* If you purchased this turntable in a package that included the cartridge, this has already been done for you.

Install the cartridge into the aluminium headshell, using the appropriate hardware included with your cartridge. All cartridges with half inch mounting holes can be fitted.

Connect the cartridge as indicated below:

- White left channel L+
- Red right channel R+
- Green right channel R-
- Blue left channel L-

For correct cartridge alignment, use the two-point cartridge alignment protractor provided with your T2 Super Phono accessories. If unfamiliar with two-point setup, please refer to your dealer.

A damaged or worn stylus may harm your record collection and should be replaced.

Please remove stylus protection before pulling the stylus from the cartridge and replace for a new one.

Stylus type is exchange for pre-mounted cartridge Sumiko Rainier: Stylus Sumiko Rainier. If in doubt, consult your local dealer or distributor.

3. Vertical Tracking Force setting (VTF)

The T2 Super Phono comes with the counterweight already assembled on the tonearm, and the tracking force is factory pre-adjusted.

To adjust or fine tune the tracking force manually, loosen the hexagonal screw on top of the counterweight (7) using the allen key provided. Remove the stylus protection cover and place the stylus pressure gauge onto the platter. To set the required VTF, lower the tonearm lift lever (10) as indicated in the illustration and place the tip of the stylus on one of the points on the scale. For example, the Sumiko Rainier requires **20mN** of tracking force, so place the stylus on the 20mN point.

If the stylus gauge becomes level when the tonearm is lowered down onto the desired point, then the correct pressure has been achieved. However, if there is insufficient or excessive pressure, the gauge will either not move or tilt down.

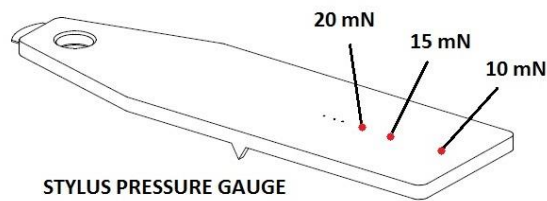

To adjust the amount of pressure, carefully move the counterweight (7) along the support rod, until the stylus pressure is sufficient to raise the pressure gauge to the level position. Moving the counterweight (7) away from the cartridge will reduce pressure and towards will increase pressure. Finally secure the counterweight (7) using hexagonal key provided.



4. Maintenance and cleaning

Your record player requires little or no regular maintenance. Remove dust with a slightly moistened antistatic cloth. Never use a dry cloth because this will create static electricity which attract more dust! Antistatic cleaning fluids are available at specialist stores but must be applied sparingly to avoid damage to rubber parts. It is recommended to fit the needle cover before cleaning or maintenance is carried out to avoid damage.

If the player is not used over a long period of time the drive belt can be removed to prevent unequal stretching.

5. Switching on and off, changing replay speed

The turntable is equipped with a three-position switch for ON/OFF and electronic speed change. To play records at 33 rpm. press this switch (3) to the rear side. To play records at 45 rpm. press this switch (3) to the front side as shown on illustration below.

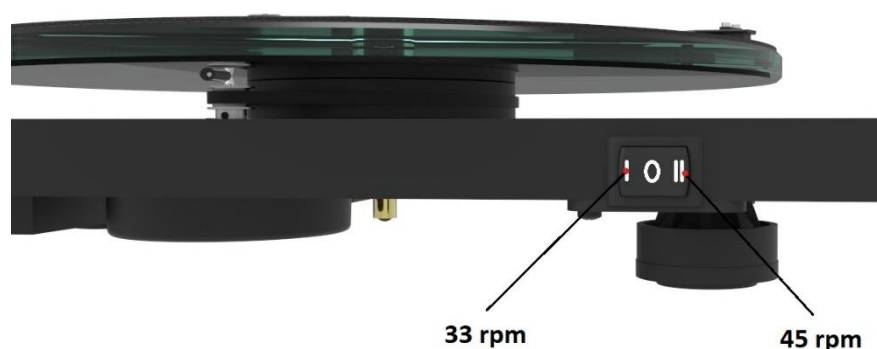

6. Anti-skating

The anti-skating force is pre-adjusted from the factory corresponding to the tracking force. Sumiko Rainier recommended tracking force 20mN = anti-skating set to 2 (middle position). You can adjust the anti-skating by rotating the anti-skating setting screw to the left or right.

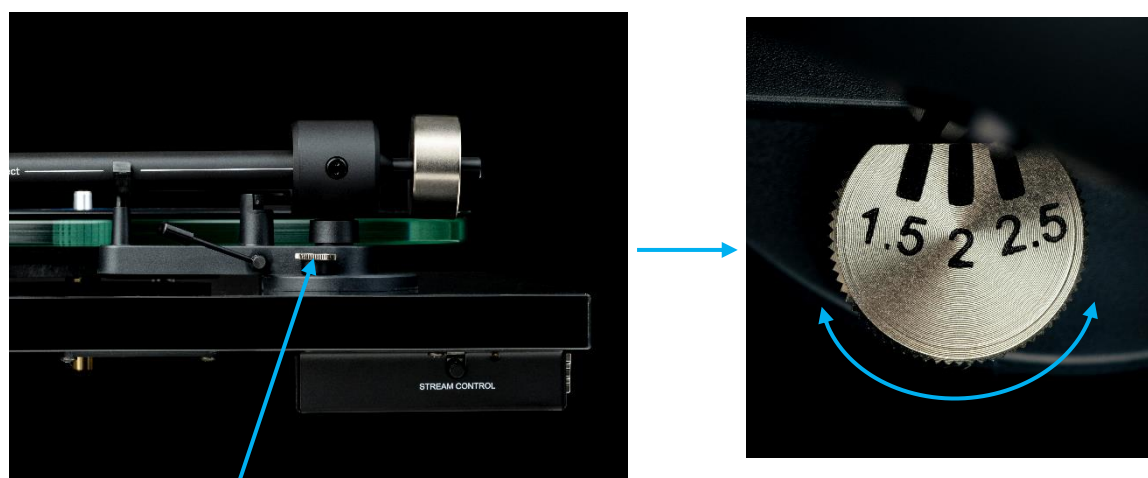

Anti-skating setting screw

7. Connection to the amplifier

The record player has gold-plated female RCA phono sockets (17) and the possibility to choose between Phono and LINE output. With LINE OUT on, you can use a line input (such as AUX, CD, Tuner, Tape, or Video) on your amplifier. With PHONO OUT on, you can use your own phono pre-amplifier (sometimes labelled gram, disc, or RIAA). Be sure to connect the left and right channels correctly. The right channel is usually marked red, and the left channel is black or white. Check the manual supplied with your amplifier for relevant information. The earthing wire of the tonearm lead should be connected to the earth terminal on your amplifier (if provided).



For detailed product information regarding Pro-Ject Audio phono amplifiers please refer to the Pro-Ject web site www.project-audio.com.



The recommended load impedance for the factory fitted cartridge is: **47kohms/MM-input**

Technical specifications Pro-Ject T2 Super Phono / Pro-Ject 9''

Nominal speeds	33/45 r.p.m.
Speed variance	33: $\pm 0.60\%$ 45: $\pm 0.50\%$
Wow and flutter	33: $\pm 0.19\%$ 45: $\pm 0.17\%$
Signal to noise	-67dB
Effective tonearm mass	9.5g
Effective tonearm length	9" (230mm)
Overhang	22 mm
Power consumption	4.5W
Power input	15V/ 0.8 A DC, universal power supply
Dimensions (W x H x D)	457 x 134 x 335mm
Weight	5.5kg
Dimensions packaging (W x H x D)	542 x 300 x 412mm
Weight incl. packaging	8.5kg

Technical specifications MM-Cartridge Sumiko Rainier

Frequency range	15-25.000Hz
Channel separation	25dB/1kHz
Output voltage	5mV
Recommended load impedance	47kohms/amplifier connection – MM-input
Compliance/stylus type	10 \times 10-6cm/dyn @ 100Hz– elliptical
Recommended tracking force	20mN
Capacitance	100pF – 200pF
Weight	6.5g

Technical specifications MM phono pre-amplifier

Gain	42dB
Output voltage typically	630mV/1kHz at 5mV/1kHz input
Input impedance	47kohms/50pF
Noise floor	-75dB
RIAA-equalisation curve accuracy	20Hz-20kHz / max. 0.3dB

Potential incorrect use and fault conditions

Pro-Ject turntables are manufactured to the highest standards and undergo strict quality controls before leaving the factory. Faults that may possibly occur are not necessarily due to material or production faults but can sometimes be caused by incorrect use or unfortunate circumstances. Therefore, the following list of common fault symptoms is included.

The platter doesn't turn although the unit is switched on:

- The unit is not connected to the mains power supply.
- No mains at the socket.
- Drive belt is not fitted or has slipped off.

No signal through one or other channel or both channels:

- No signal contact from the cartridge to the internal tonearm wiring or from that to the arm lead or from that to the phono box or between that and the amplifier. This could be due to a faulty plug, broken wire or solder joint or simply loose plug/socket connection.
- Correct input not selected at amplifier.
- Amplifier is not switched on.
- Amplifier or speakers are defective or muted.
- No connection to the loudspeakers.

Distorted or inconsistent sound from one or both channels:

- Record player is connected to wrong input of amplifier.
- Needle or cantilever damaged.
- Wrong r.p.m., drive belt overstretched or dirty, platter bearing without oil, dirty or damaged.

Service

Should you encounter a problem which you are not able to alleviate or identify despite the above information, please contact your dealer for further advice. Only when the problem cannot be resolved there should the unit be sent to the responsible distributor in your country.

Guarantee repairs will only be affected if the unit is returned correctly packaged. For this reason, we recommend keeping the original packaging.

Never return a record player without making sure that it is safely disassembled and correctly packaged in the original packaging according to the diagrams on the last page of this user guide. Please remove these parts and pack them separately: lid, counterweight, anti-skating weight and belt.

Fit the cartridge protection cap and the transport lock for the tonearm tube, prior to carefully packaging the record player.

Warranty



The manufacturer accepts no responsibility for damage caused by not adhering to these instructions for use and/or by transportation without the original packaging. Modification or change to any part of the product by unauthorized persons, release the manufacturer from any liability over and above the lawful rights of the customer.

Pro-Ject Audio Systems is a Registered Trademark of H. Lichtenegger.

This guide was produced by: Pro-Ject Audio Systems
Copyright © 2024. All rights reserved.

The information was correct at the time of going to press. The manufacturer reserves the right to make changes to the technical specification without prior notice as deemed necessary to uphold the ongoing process of technical development.

Declaration of Conformity

We, **SEV Litovel, s r.o.**
Palackého 1160/34
78401 Litovel
Czech Republic
(manufacturer)

and

Pro-Ject Audio Systems a division of Audio Tuning GmbH
Margaretenstrasse 98
1050 Vienna,
Austria
(distributor)

declare under our responsibility that the product is in conformity with the provisions of Directives:
2014/35/EU including amendments
2014/30/EU including amendments
2014/53/EU including amendments

The following harmonised standards were applied:

Health: EN62479:2010

Safety: EN60950-1:2006+A11:2009+A1:2010+A12:2011+A2:2013, EN62368-1:2014/A11:2017,
EN61558-1:2005/A1:2009, EN61558-2-16:2009/A1:2013

EMC: EN301489-1 V2.2.0: 2017-03, EN301489-17 V3.2.0:2017-03, EN55032:2015, EN55035:2017,
EN61000-3-2:2014, EN61000-3-3:2013

Radio Spectrum: EN300328 V2.1.1 (2016-11)

Pro-Ject Audio Systems a division of Audio Tuning GmbH
1050 Vienna, Austria, Margaretenstrasse 98
info@project-audio.com

